



US007185309B1

(12) **United States Patent**
Kulkarni et al.

(10) **Patent No.:** **US 7,185,309 B1**
(45) **Date of Patent:** **Feb. 27, 2007**

(54) **METHOD AND APPARATUS FOR APPLICATION-SPECIFIC PROGRAMMABLE MEMORY ARCHITECTURE AND INTERCONNECTION NETWORK ON A CHIP**

(75) Inventors: **Chidamber R. Kulkarni**, San Jose, CA (US); **Gordon J. Brebner**, Monte Sereno, CA (US); **Eric R. Keller**, Boulder, CO (US); **Philip B. James-Roxby**, Longmont, CO (US)

(73) Assignee: **Xilinx, Inc.**, San Jose, CA (US)

(*) Notice: Subject to any disclaimer, the term of this patent is extended or adjusted under 35 U.S.C. 154(b) by 401 days.

2004/0006584	A1	1/2004	Vandeweerd
2004/0128120	A1	7/2004	Coburn et al.
2005/0034090	A1	2/2005	Sato et al.
2005/0114593	A1	5/2005	Cassell et al.
2005/0172085	A1	8/2005	Klingman
2005/0172087	A1	8/2005	Klingman
2005/0172088	A1	8/2005	Klingman
2005/0172089	A1	8/2005	Klingman
2005/0172090	A1	8/2005	Klingman
2005/0172289	A1	8/2005	Klingman
2005/0172290	A1	8/2005	Klingman

(Continued)

(21) Appl. No.: **10/769,591**

OTHER PUBLICATIONS

(22) Filed: **Jan. 30, 2004**

U.S. Appl. No. 10/769,330, filed Jan. 30, 2004, James-Roxby et al.

(51) **Int. Cl.**
G06F 17/50 (2006.01)

(Continued)

(52) **U.S. Cl.** **716/18; 718/2**

Primary Examiner—Thuan Do
Assistant Examiner—Binh Tat

(58) **Field of Classification Search** **716/18, 716/2, 3; 709/217; 719/313**

(74) *Attorney, Agent, or Firm*—Robert Brush

See application file for complete search history.

(57) **ABSTRACT**

(56) **References Cited**

U.S. PATENT DOCUMENTS

5,867,180	A *	2/1999	Katayama et al.	345/542
6,078,736	A	6/2000	Guccione		
6,182,183	B1	1/2001	Wingard et al.		
6,230,307	B1	5/2001	Davis et al.		
6,324,629	B1	11/2001	Kulkarni et al.		
6,405,160	B1	6/2002	Djaja et al.		
6,581,187	B2	6/2003	Gupta et al.		
6,647,431	B1 *	11/2003	Utas	719/313
6,671,869	B2 *	12/2003	Davidson et al.	716/17
6,794,896	B1	9/2004	Brebner		
6,891,397	B1	5/2005	Brebner		
6,918,103	B2 *	7/2005	Brawn et al.	716/18
2003/0033374	A1 *	2/2003	Horn et al.	709/217
2003/0126195	A1	7/2003	Reynolds et al.		
2003/0182083	A1	9/2003	Schwenke et al.		

Programmable architecture for implementing a message processing system using an integrated circuit is described. In an example, specification data is received that includes attributes of the memory system. A logical description of the memory system is generated in response to the specification data. The logical description defines a memory component and a memory-interconnection component. A physical description of the memory system is generated in response to the logical description. The physical description includes memory circuitry associated with the integrated circuit defined by the memory component. The memory circuitry includes an interconnection topology defined by the memory interconnection component.

11 Claims, 15 Drawing Sheets

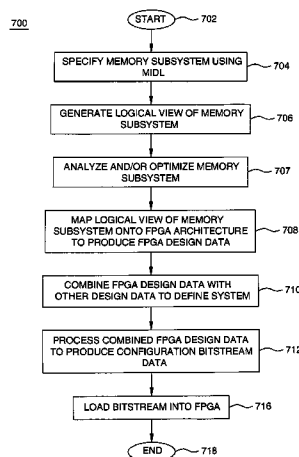

US 7,185,309 B1

Page 2

U.S. PATENT DOCUMENTS

2005/0177671 A1 8/2005 Klingman
2005/0210178 A1 9/2005 Klingman
2005/0223384 A1 10/2005 Klingman
2005/0262286 A1 11/2005 Klingman

OTHER PUBLICATIONS

U.S. Appl. No. 10/769,331, filed Jan. 30, 2004, Keller et al.
U.S. Appl. No. 10/769,592, filed Jan. 30, 2004, Brebner et al.
Gordon Brebner, "Multithreading for Logic-Centric Systems"; 12th International Conference on Field Programmable Logic and Applications; Montpellier, France; Sep. 2-4, 2002; Springer LNCS 2438; pp. 5-14.

Gordon Brebner, "Single-chip Gigabit Mixed-version IP Router on Virtex-II Pro"; Proceedings of the 10th Annual IEEE Symposium on Field-Programmable Custom Computing Machines (FCCM'02); Apr. 2002; IEEE Computer Science Press; pp. 35-44.

Xilinx, Inc.; U.S. Appl. No. 10/402,659 filed on Mar. 28, 2003 by James-Roxby.

Xilinx, Inc.; U.S. Appl. No. 10/420,652 filed on Apr. 21, 2003 by Brebner.

Xilinx, Inc.; U.S. Appl. No. 10/421,013 filed on Apr. 21, 2003 by Brebner.

* cited by examiner

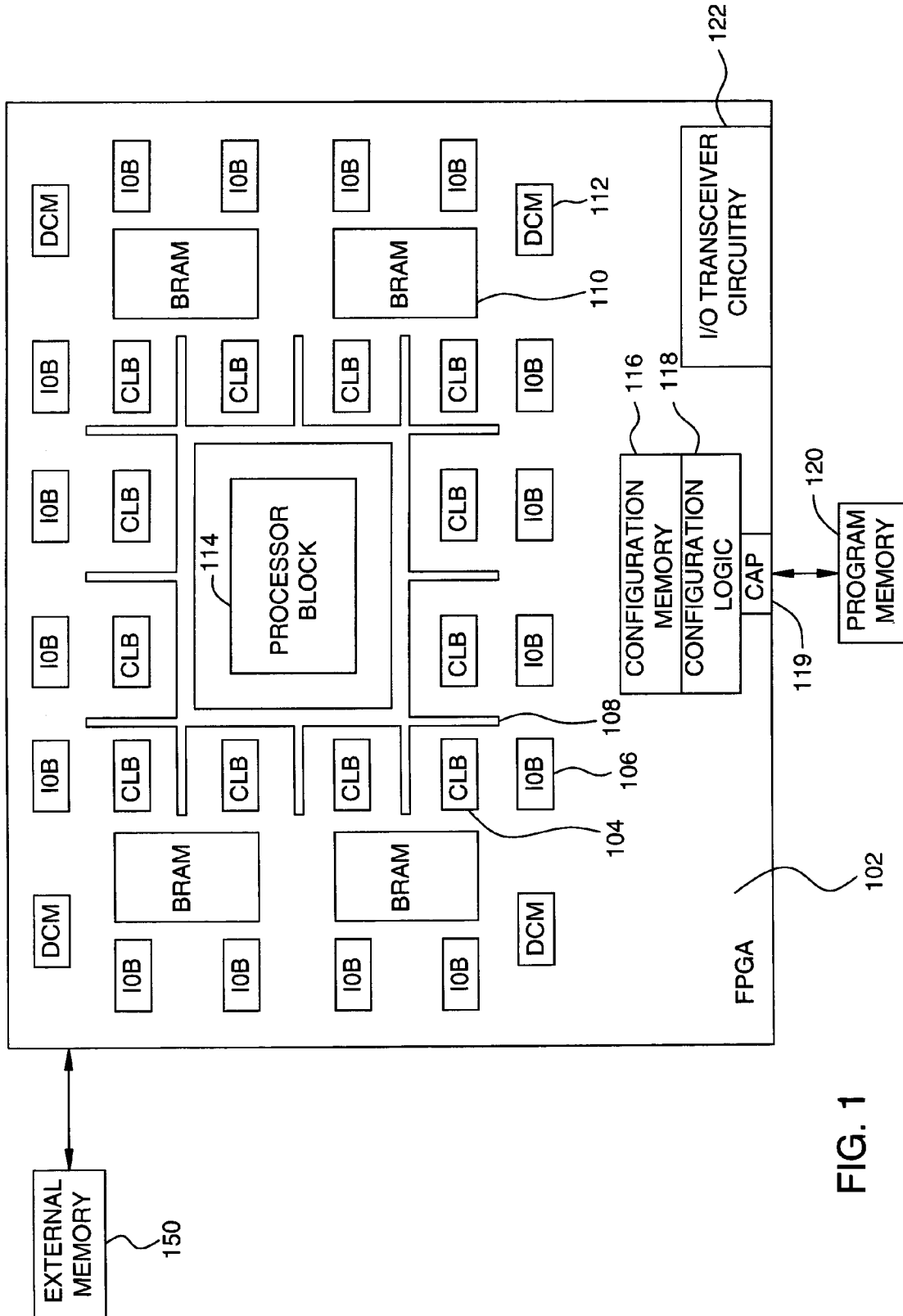
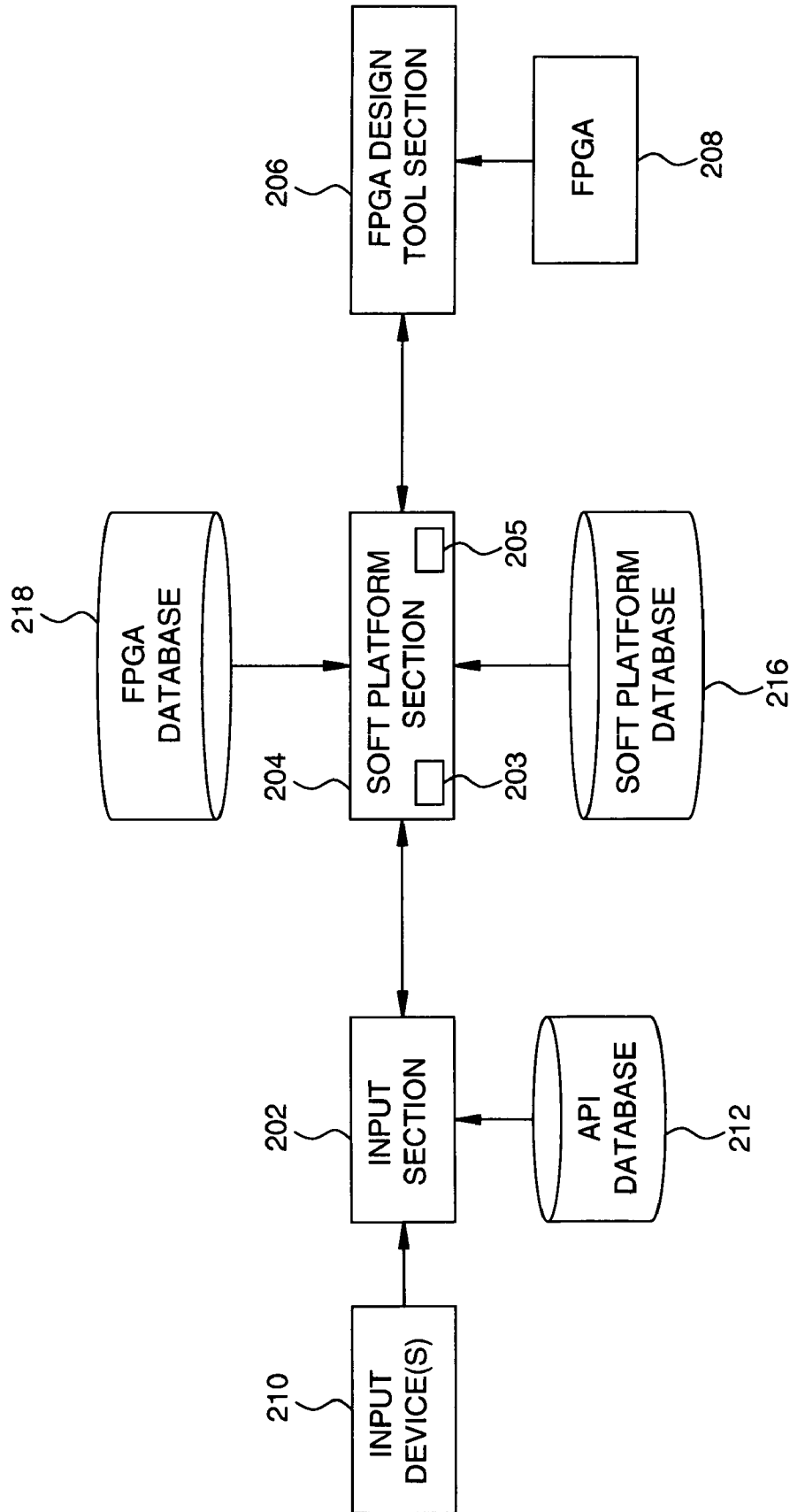

FIG. 1



200

FIG. 2

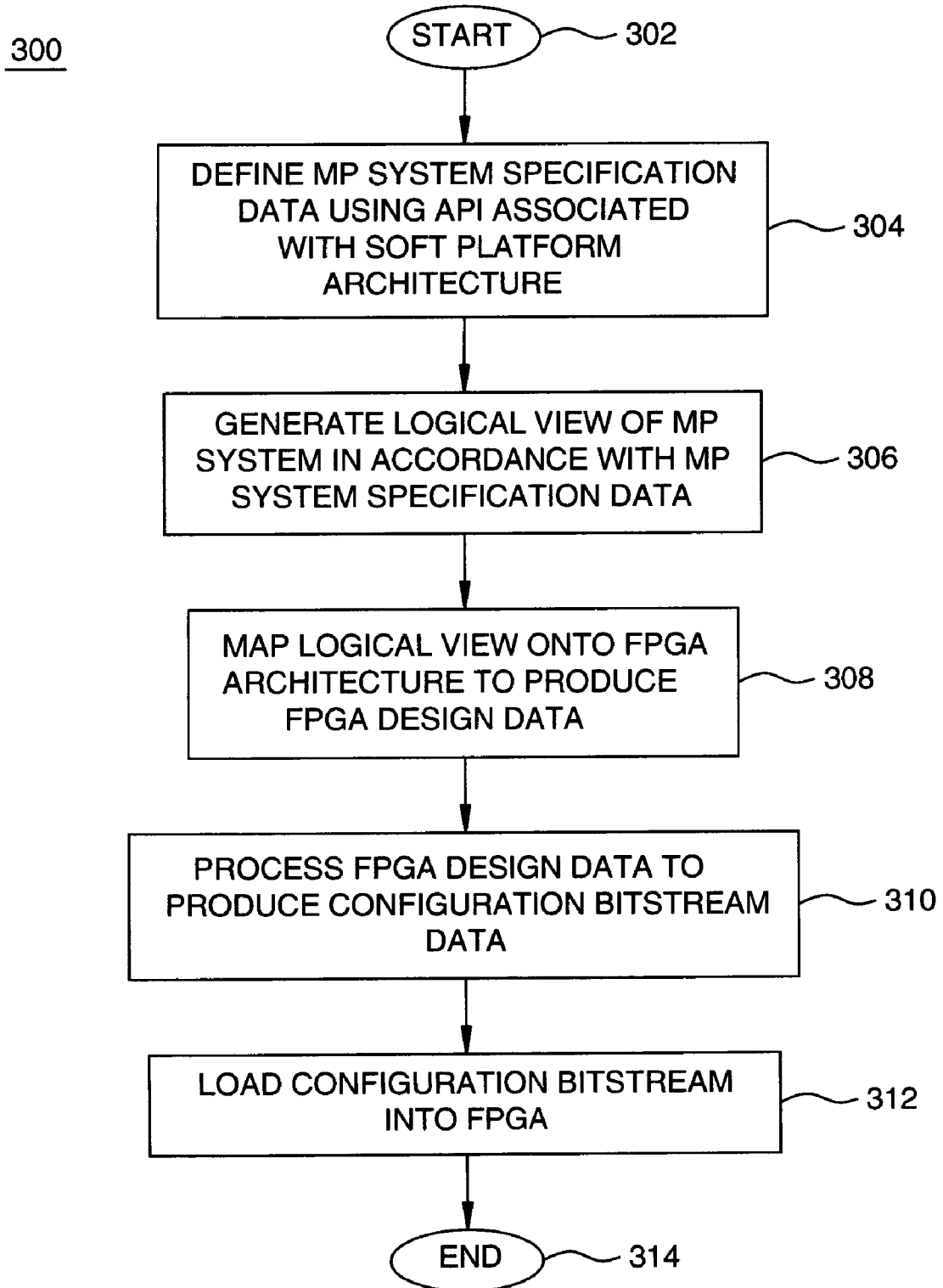

FIG. 3

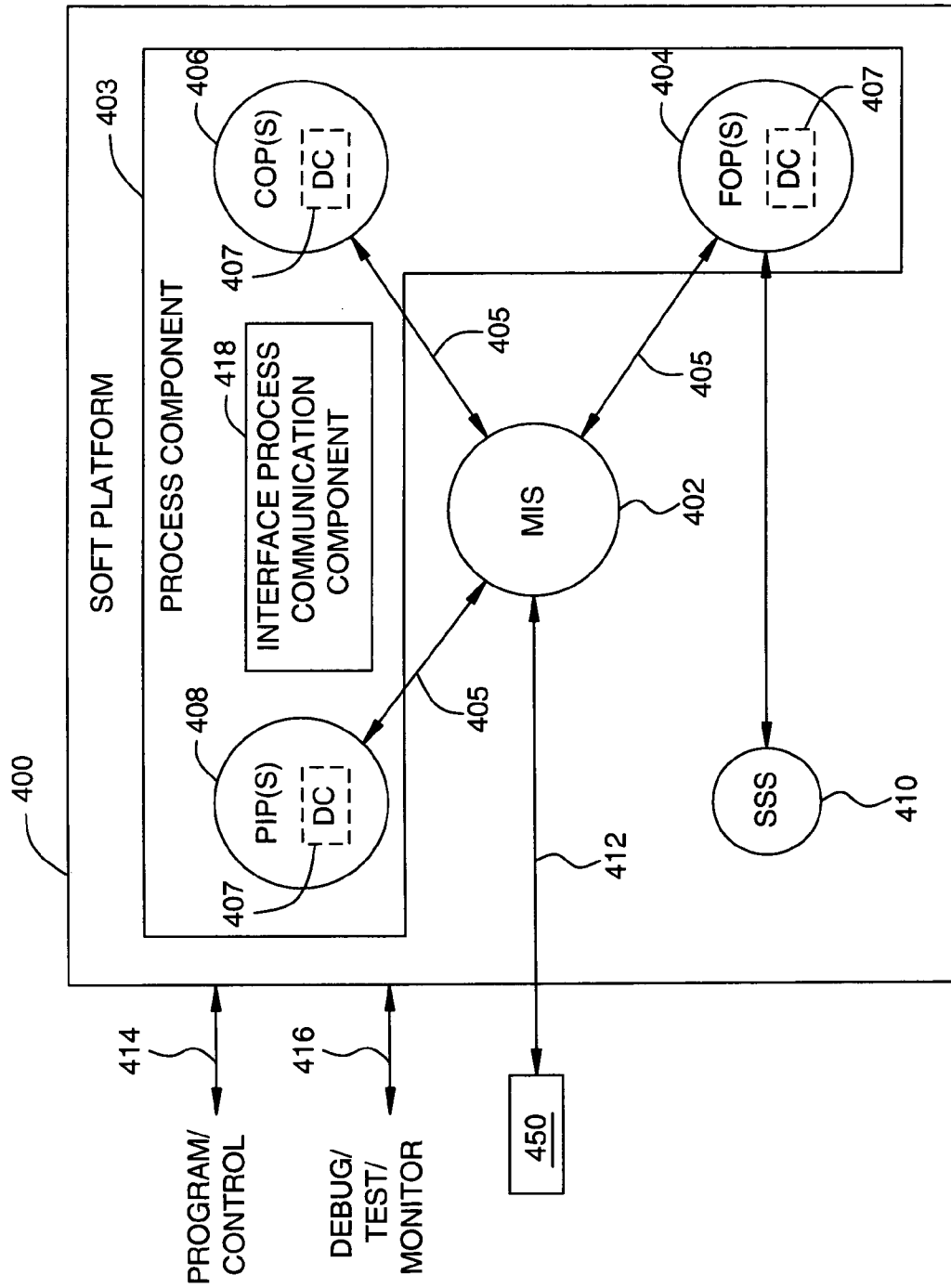
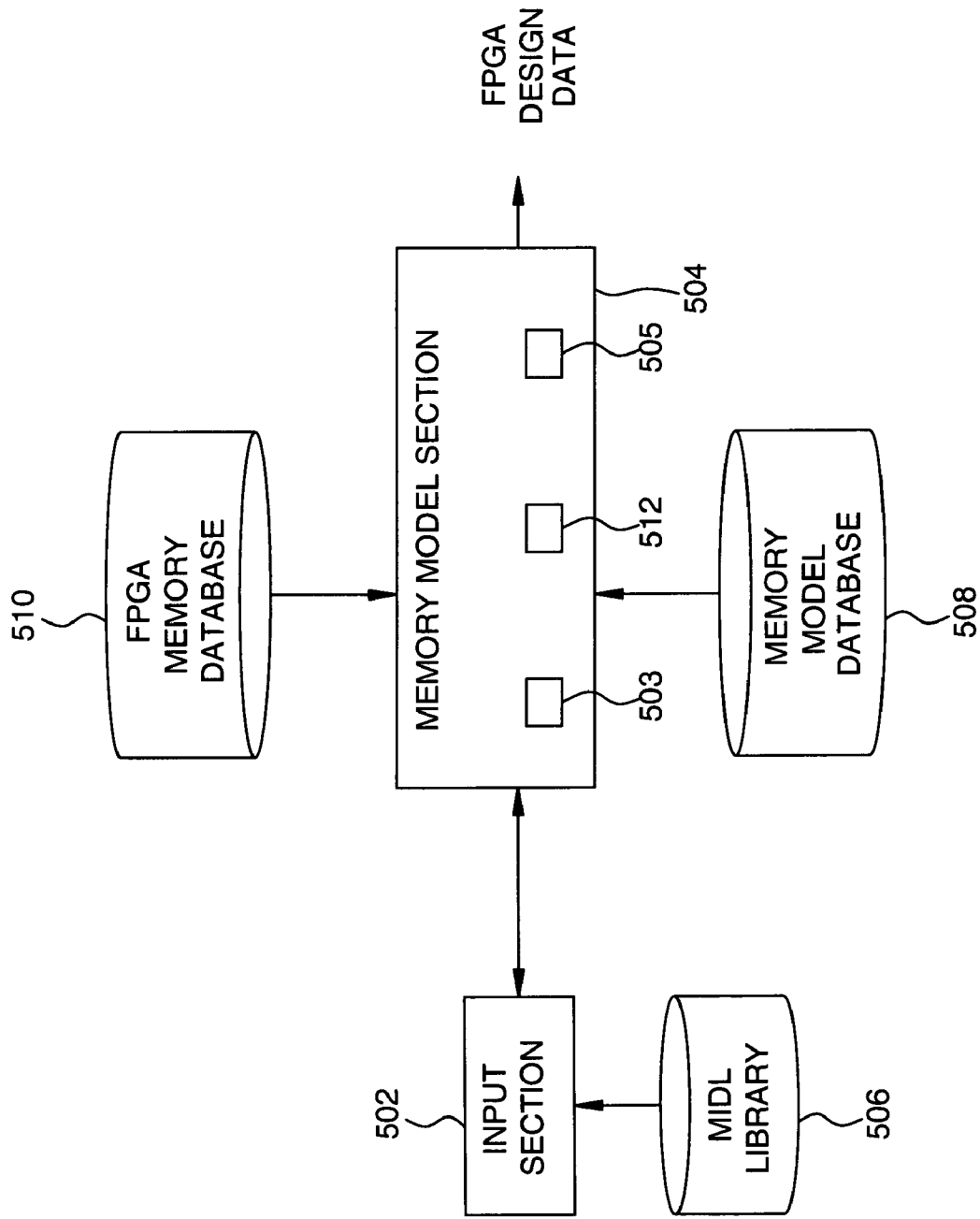

FIG. 4



500

FIG. 5

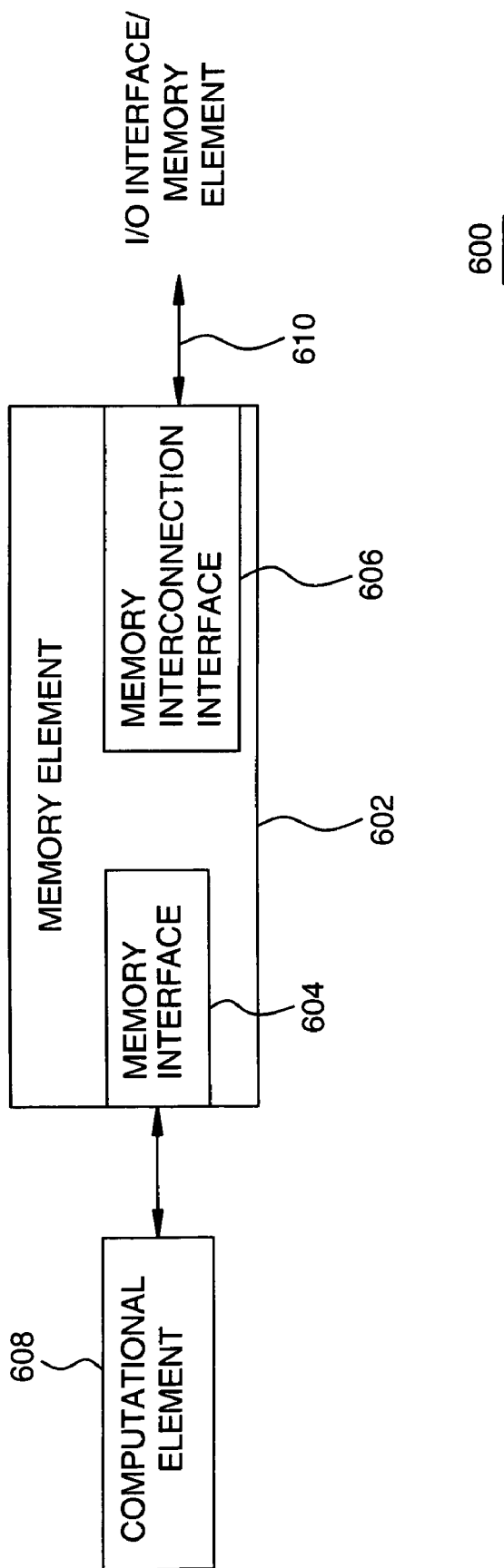

FIG. 6

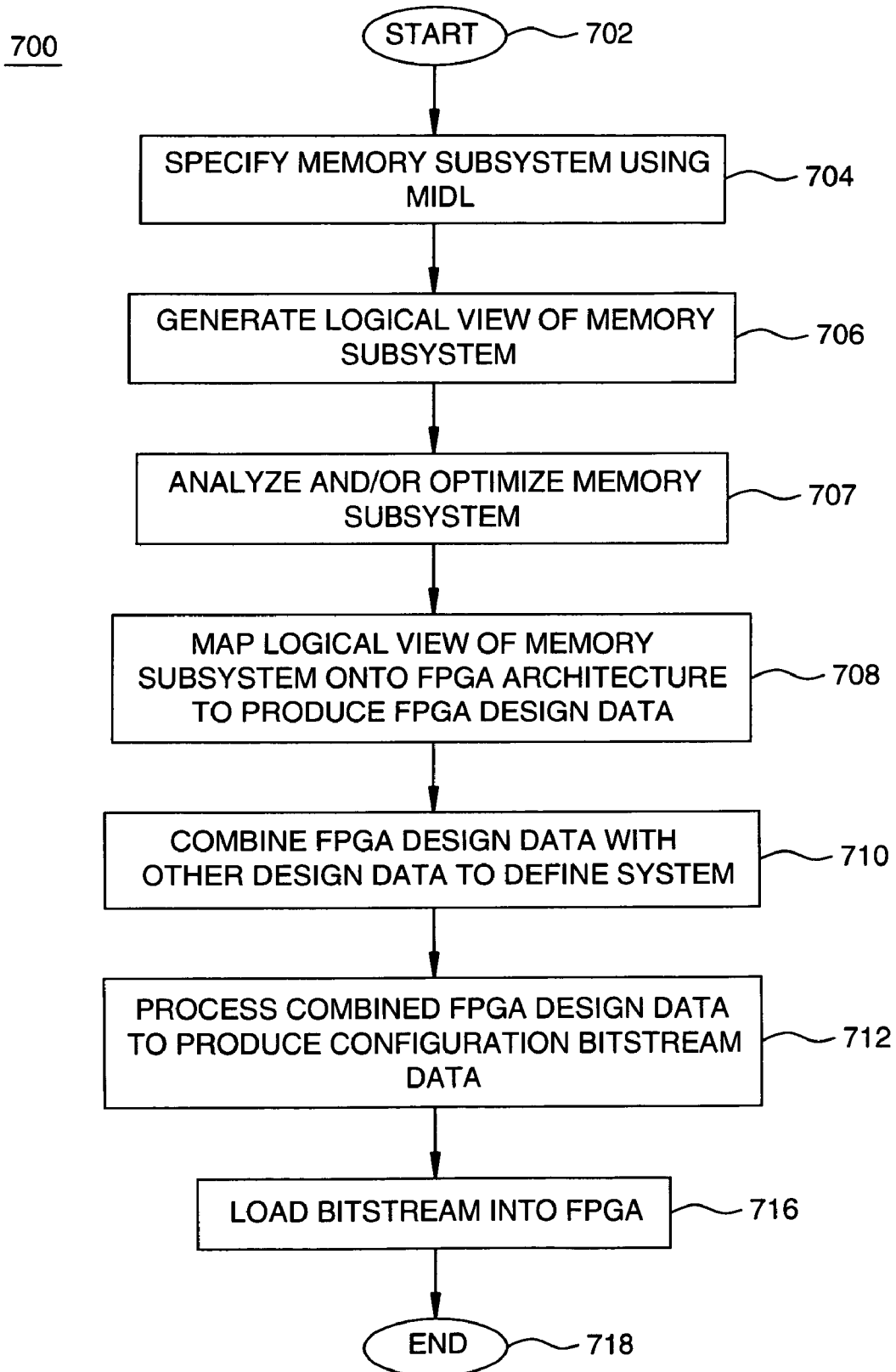

FIG. 7

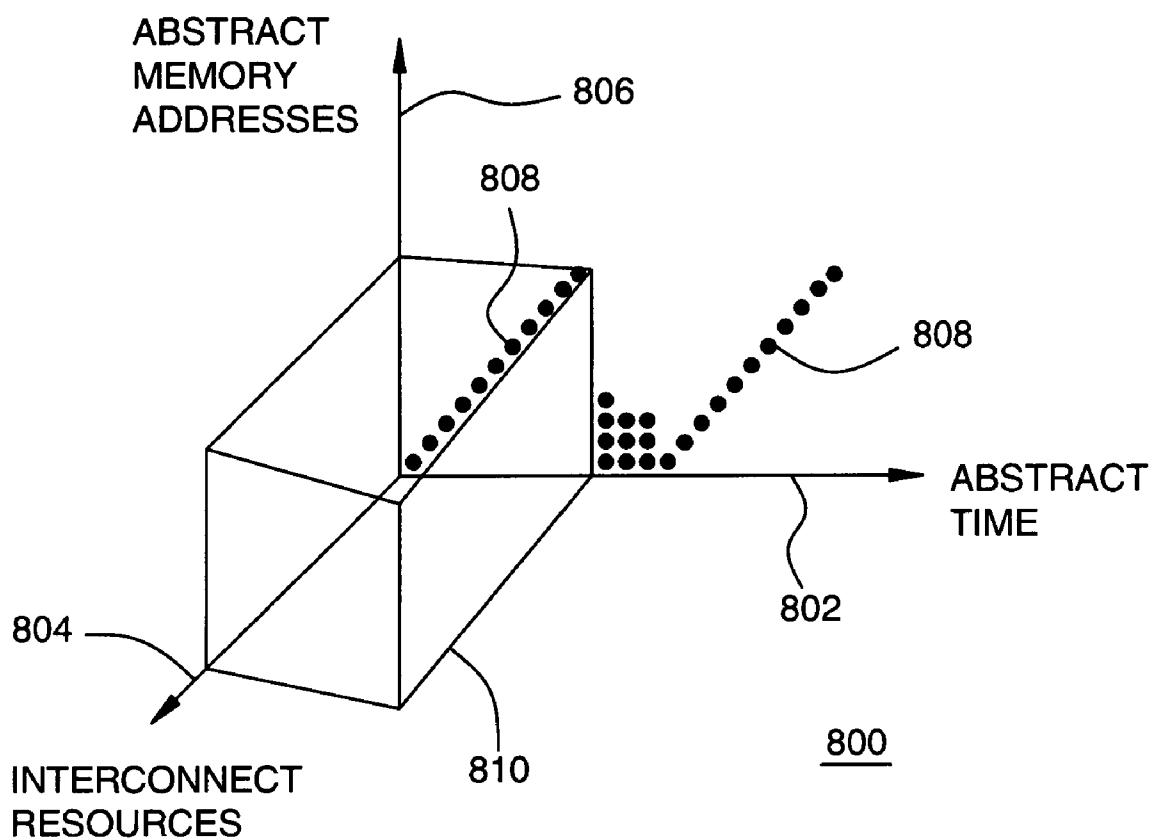

FIG. 8

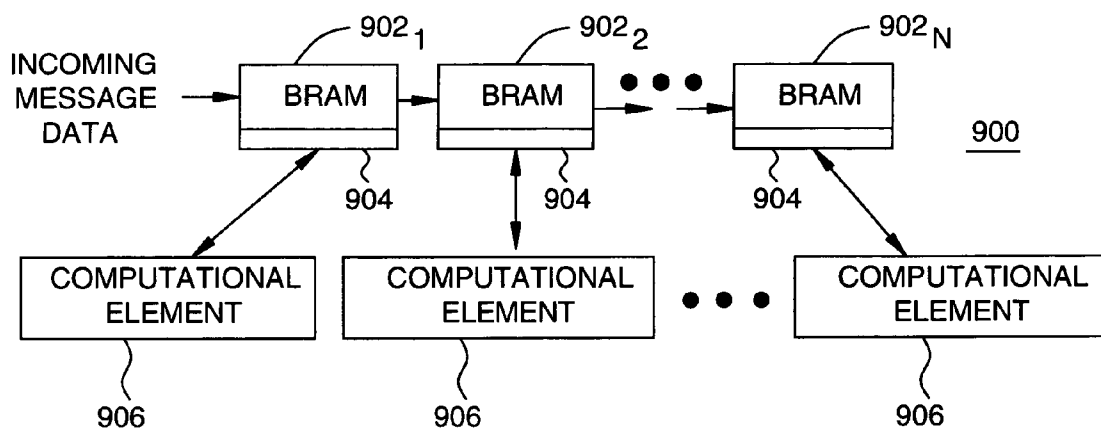

FIG. 9

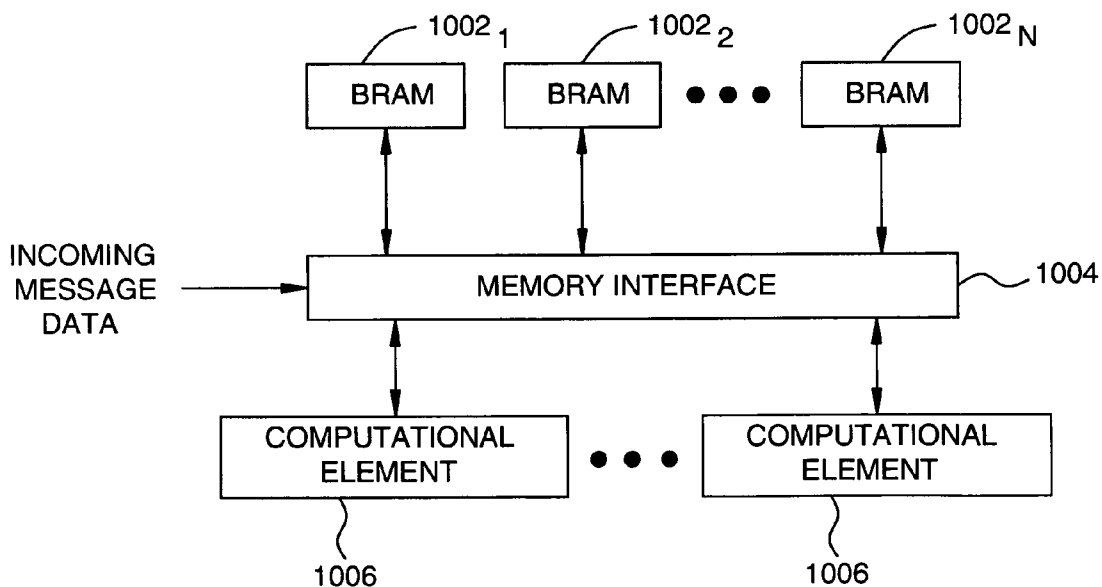

FIG. 10

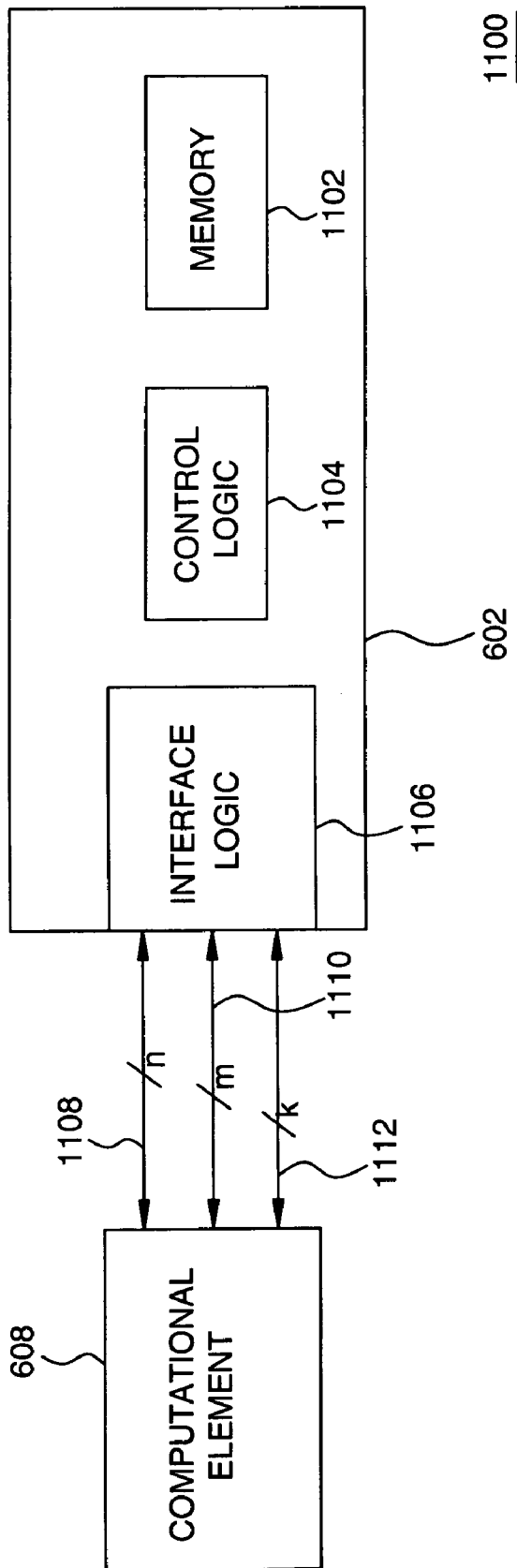

FIG. 11

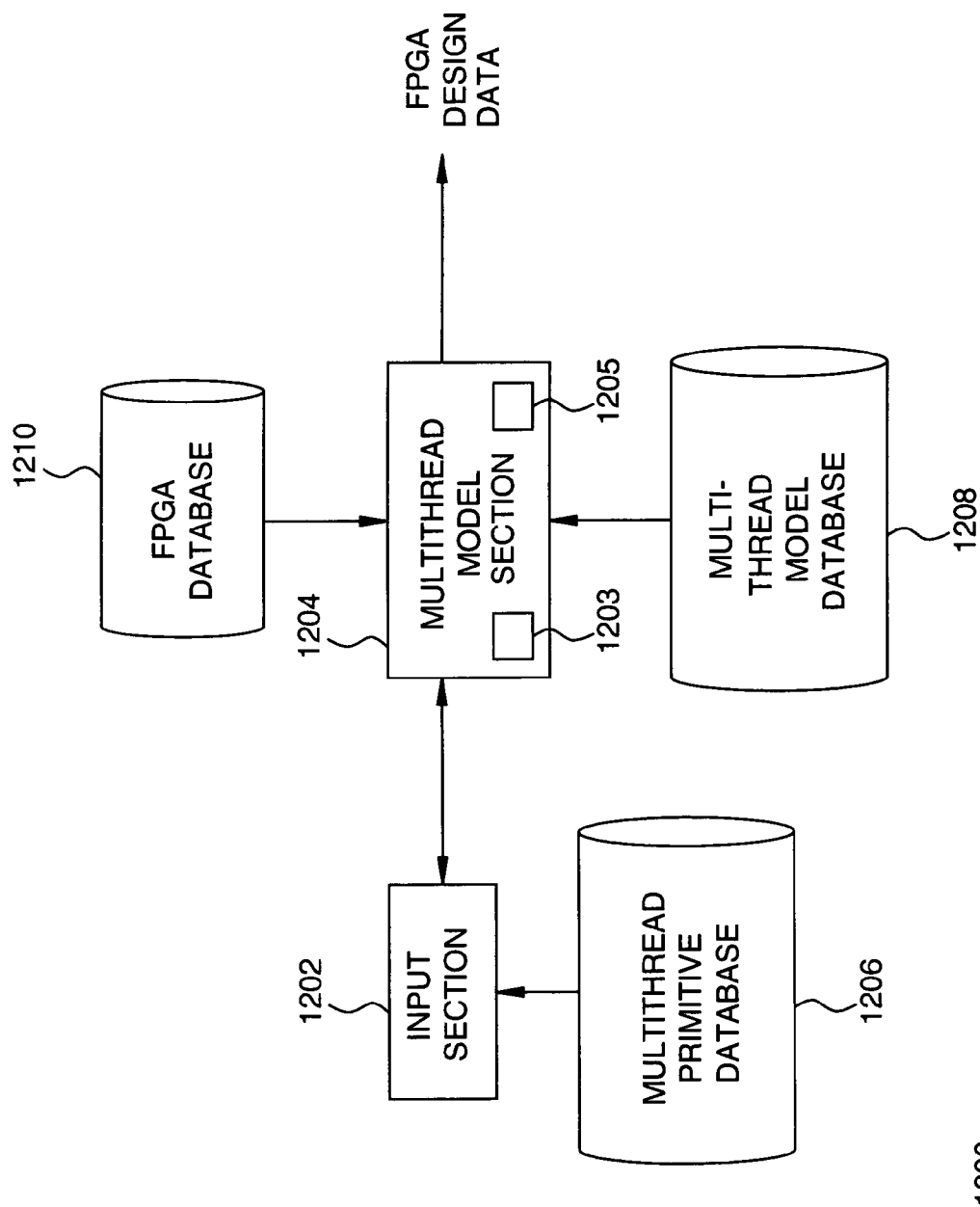

FIG. 12

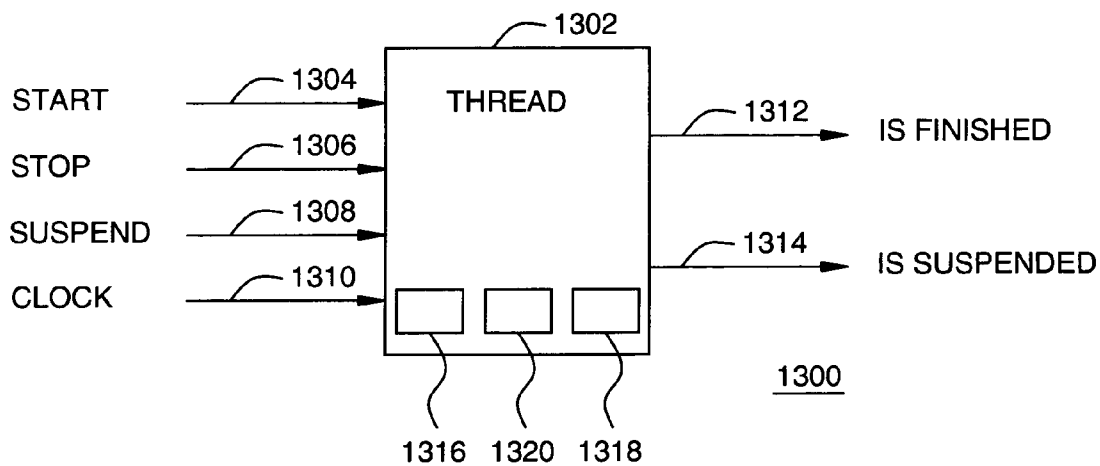

FIG. 13

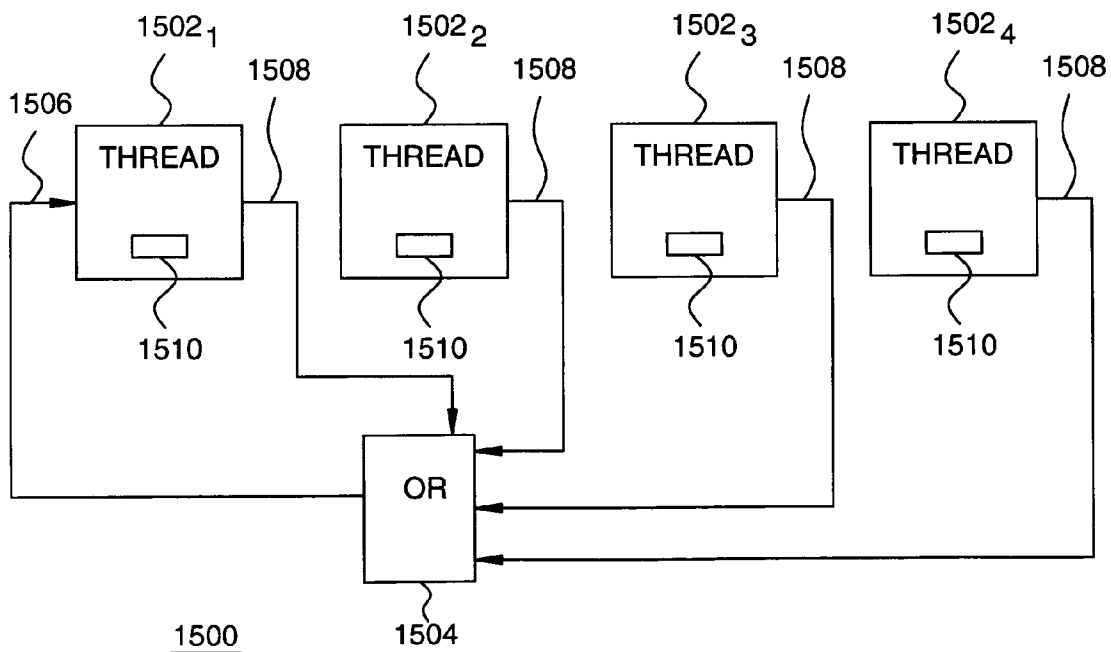

FIG. 15

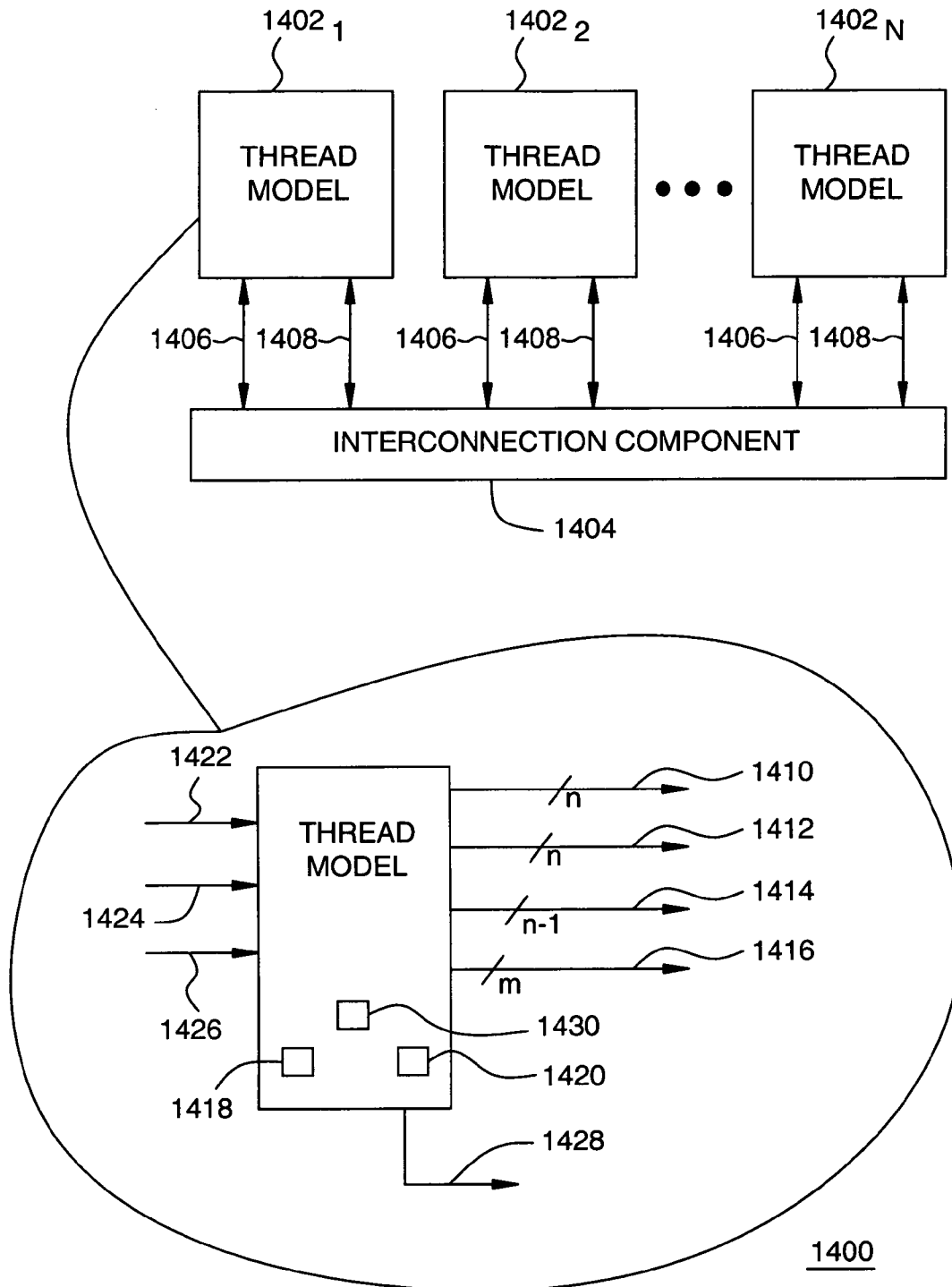

FIG. 14

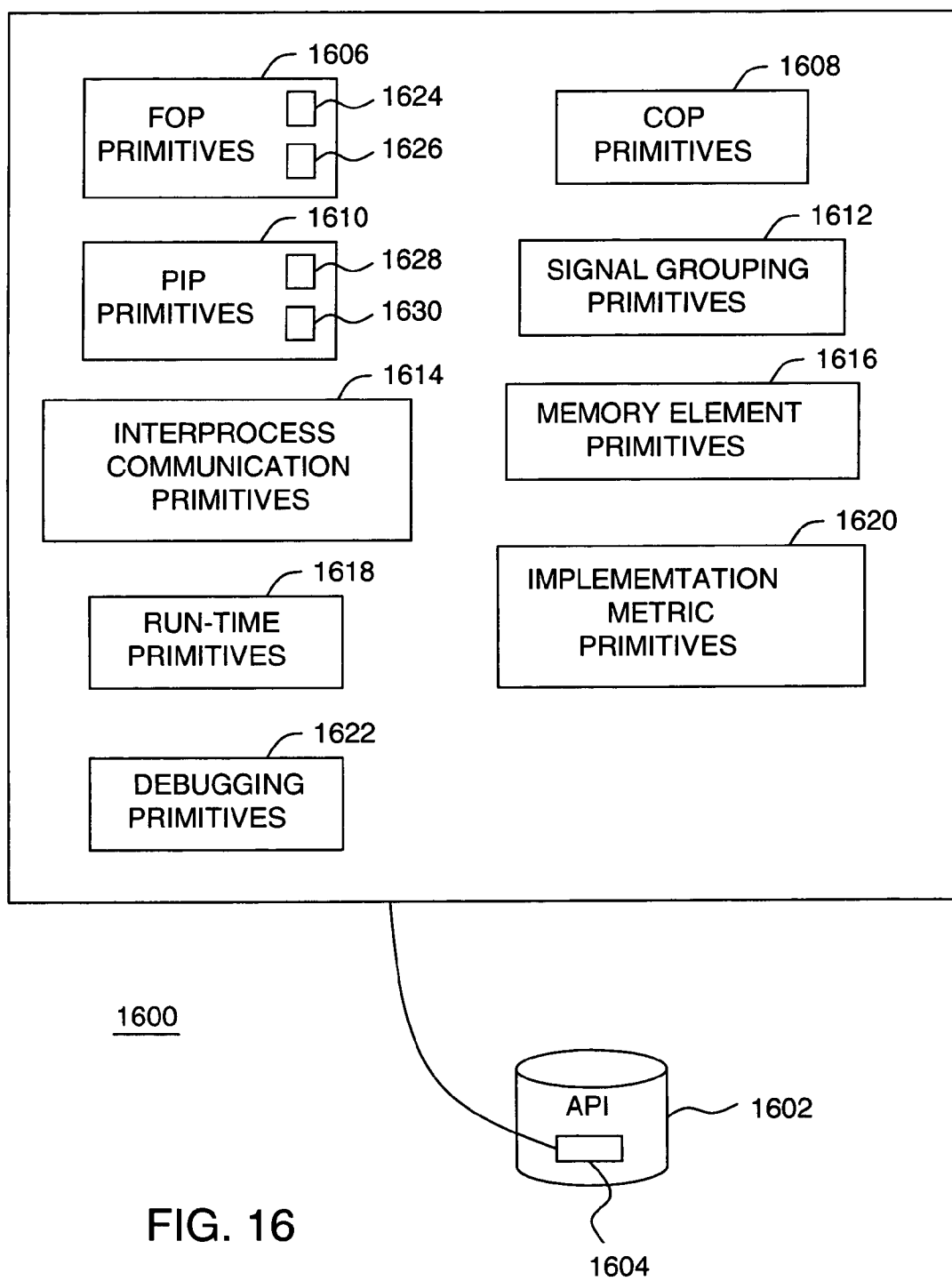

FIG. 16

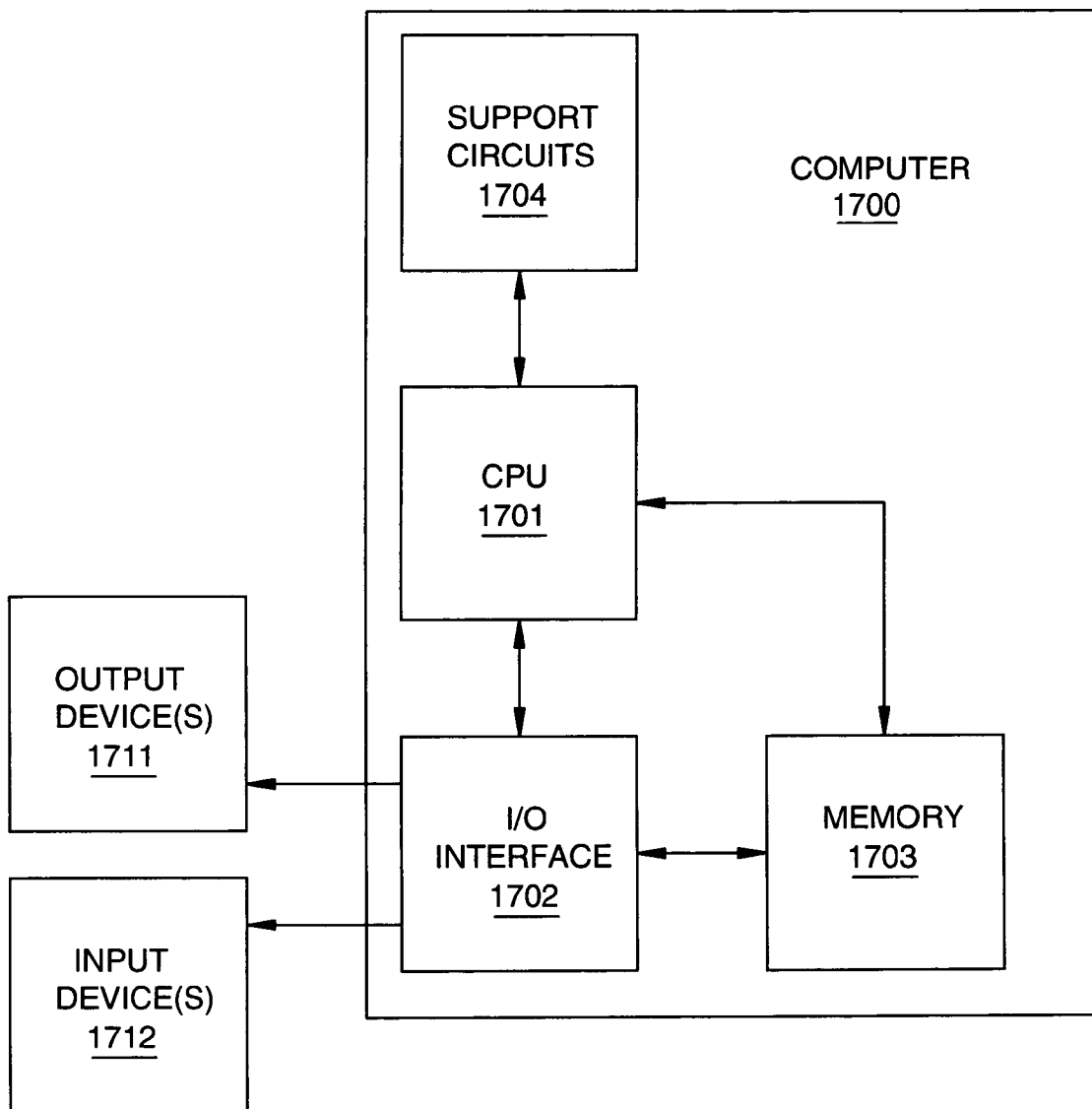

FIG. 17

1

**METHOD AND APPARATUS FOR
APPLICATION-SPECIFIC PROGRAMMABLE
MEMORY ARCHITECTURE AND
INTERCONNECTION NETWORK ON A CHIP**

FIELD OF THE INVENTION

One or more aspects of the present invention relate generally to integrated circuit design tools and, more particularly, to a programmable architecture for implementing a message processing system using an integrated circuit.

BACKGROUND OF THE INVENTION

Programmable logic devices (PLDs) exist as a well-known type of integrated circuit (IC) that may be programmed by a user to perform specified logic functions. There are different types of programmable logic devices, such as programmable logic arrays (PLAs) and complex programmable logic devices (CPLDs). One type of programmable logic device, known as a field programmable gate array (FPGA), is very popular because of a superior combination of capacity, flexibility, time-to-market, and cost.

An FPGA typically includes an array of configurable logic blocks (CLBs) surrounded by a ring of programmable input/output blocks (IOBs). The CLBs and IOBs are interconnected by a programmable interconnect structure. The CLBs, IOBs, and interconnect structure are typically programmed by loading a stream of configuration data (known as a bitstream) into internal configuration memory cells that define how the CLBs, IOBs, and interconnect structure are configured. Additionally, an FPGA may include embedded memory, such as block random access memories (BRAMs), one or more microprocessors, sometimes referred to as embedded cores, and digital clock managers (DCMs). The combination of components on an FPGA may be used for system-level integration, sometimes referred to as "system-on-a-chip" (SOC).

Historically, FGPA's have not been employed in network processing applications. Rather, Network devices, such as routers, employ dedicated, special purpose components for processing packets that propagate through the network. Conventionally, network devices employ network processors or application specific integrated circuits (ASICs) to provide the desirable packet processing/network processing functions. Such processor- or ASIC-based architectures, however, are static in nature, providing a fixed amount of resources for packet processing/network processing functions. Accordingly, there exists a need in the art for more flexible message processing architectures.

SUMMARY OF THE INVENTION

One aspect of the invention relates to designing a memory system for implementation using an integrated circuit. Specification data is received that includes attributes of the memory system. A logical description of the memory system is generated in response to the specification data. The logical description defines a memory component and a memory-interconnection component. A physical description of the memory system is generated in response to the logical description. The physical description includes memory circuitry associated with the integrated circuit defined by the memory component. The memory circuitry includes an interconnection topology defined by the memory interconnection component.

2

Another aspect of the invention relates to a design tool for designing a memory system for implementation using an integrated circuit. An input section is adapted to specify attributes of the memory system. A first database stores a memory model defining a memory component and a memory interconnection component. A second database stores a physical memory configuration associated with the integrated circuit. A memory model section includes a first portion and a second portion. The first portion is adapted to generate an instance of the memory component and an instance of the memory-interconnection component. The second portion is adapted to implement the memory component instance and the memory-interconnection component instance in terms of memory circuitry and interconnection circuitry, respectively, of the physical memory configuration to produce a physical view of the memory system.

BRIEF DESCRIPTION OF THE DRAWINGS

Accompanying drawing(s) show exemplary embodiment(s) in accordance with one or more aspects of the invention; however, the accompanying drawing(s) should not be taken to limit the invention to the embodiment(s) shown, but are for explanation and understanding only.

FIG. 1 is a block diagram depicting an exemplary embodiment of an FPGA coupled to external memory and a program memory;

FIG. 2 is a block diagram depicting an exemplary embodiment of a design tool for designing a message processing system for implementation using an FPGA;

FIG. 3 is a flow diagram depicting an exemplary embodiment of a process for designing a message processing system for implementation within an FPGA;

FIG. 4 is a block diagram depicting an exemplary embodiment of a soft platform architecture in accordance with one or more aspects of the invention;

FIG. 5 is a block diagram depicting an exemplary embodiment of a design tool for designing a memory subsystem for implementation using an FPGA;

FIG. 6 is a block diagram depicting an exemplary embodiment of a memory model in accordance with one or more aspects of the invention;

FIG. 7 is a flow diagram depicting an exemplary embodiment of a process for designing a memory subsystem for implementation using an FPGA;

FIG. 8 is a graph illustrating an exemplary embodiment of a memory analysis model;

FIG. 9 is a block diagram depicting an exemplary embodiment of a memory subsystem that may be implemented using the memory model of FIG. 6;

FIG. 10 is a block diagram depicting another exemplary embodiment of a memory subsystem that may be implemented using the memory model of FIG. 6;

FIG. 11 is a block diagram depicting an exemplary embodiment of a cooperative memory interface that may be implemented using the memory model of FIG. 6;

FIG. 12 is a block diagram depicting an exemplary embodiment of a design tool for designing a multithread model for implementation using an FPGA;

FIG. 13 is a block diagram depicting an exemplary embodiment of a thread model in accordance with one or more aspects of the invention;

FIG. 14 is a block diagram depicting an exemplary embodiment of a multithread model in accordance with one or more aspects of the invention;

FIG. 15 is a block diagram depicting an exemplary embodiment of a multithread system that may be implemented using the multithread model of FIG. 14;

FIG. 16 is a block diagram depicting an exemplary embodiment of a programming interface for the soft platform architecture described herein; and

FIG. 17 is a block diagram depicting an exemplary embodiment of a computer suitable for implementing processes, methods, and system sections described herein.

DETAILED DESCRIPTION OF THE DRAWINGS

To facilitate understanding of the invention, the description has been organized as follows:

Overview, introduces aspects of the invention and exemplary embodiments of their relationships to one another;

Soft Platform, describes a programmable architecture and associated design tool for implementing a message processing system using an integrated circuit;

Memory Model, describes an application-specific programmable memory architecture and interconnection network for an integrated circuit;

Multithread Model, describes an inter-process synchronization mechanism for threads implemented within a configurable logic portion of an integrated circuit; and

Programming Interface, describes a programming interface for a design tool embodying a soft architecture for implementing a message processing system using an integrated circuit.

Overview

One or more aspects of the invention are related to a configurable and programmable micro-architecture for implementing message-processing (MP) systems (“soft platform architecture”). As used herein, the term “message” encompasses packets, cells, frames, data units, and like type blocks of information known in the art that is passed over a communication channel. A “message-processing” system is a system or subsystem for processing messages (e.g., a packet processing system or a network processing system). The soft platform architecture is “message-centric” to match the nature of MP systems. That is, the processing components of the MP system go to the messages, as opposed to the messages going to the processing components.

Briefly stated, a designer specifies attributes for an MP system, such as structural and behavioral attributes for processing components and memory components. For example, the designer may employ a set of descriptions or “primitives” that parametrically define the MP system attributes. The primitives provide an abstract mechanism for defining the MP system. A design tool embodying the soft platform architecture may include a programming interface for generating a logical description or “logical view” of an MP system based on the designer-specified attributes.

Notably, the logical view includes logical components of the soft platform architecture configured in accordance with the designer-specified MP system. In particular, the soft platform architecture includes a memory model component and a multithreading component. A physical view of the MP system may then be generated based on the logical view. The physical view includes physical components of an integrated circuit architecture that implement the logical components of the soft platform architecture. The physical view may then be processed to generate configuration data for the integrated circuit to realize the designer-specified MP system (e.g., a configuration bitstream for a PLD or mask data for an ASIC). Thus, the soft platform architecture provides

a mechanism by which a designer may design an MP system in an abstract fashion, without knowledge of the particular physical configuration of the integrated circuit.

One or more aspects of the invention are described with respect to a programmable architecture for implementing a message processing system using an FPGA. While the invention is described with specific reference to an FPGA, those skilled in the art will appreciate that other types of programmable logic devices may be used, such as complex programmable logic devices (CPLDs). In addition, other types of mask-programmable devices may be used, such as application specific integrated circuits (ASICs). Those skilled in the art will appreciate that, if an ASIC is employed rather than an PLD, then mask data is generated in place of a configuration bitstream.

FIG. 1 is a block diagram depicting an exemplary embodiment of an FPGA 102 coupled to external memory 150 and a program memory 120. The external memory 150 may comprise, for example, synchronous dynamic RAM (SDRAM), double-data rate SDRAM (DDR SDRAM), Rambus® RAM (RDRAM), and the like. For purposes of clarity by example, the memory 150 is referred to as “external” in that the memory 150 is not part of the FPGA 102. It is to be understood, however, that the external memory 150 and the FPGA 102, as well as various other devices, may be integrated onto a single chip to form a single system-level integrated circuit (referred to as a “system-on-a-chip” or SoC).

The FPGA 102 illustratively comprises programmable logic circuits or “blocks”, illustratively shown as CLBs 104, IOBs 106, and programmable interconnect 108 (also referred to as “programmable logic”), as well as configuration memory 116 for determining the functionality of the FPGA 102. The FPGA 102 may also include an embedded processor block 114, as well as various dedicated internal logic circuits, illustratively shown as blocks of random access memory (“BRAM 110”), configuration logic 118, digital clock management (DCM) blocks 112, and input/output (I/O) transceiver circuitry 122. Those skilled in the art will appreciate that the FPGA 102 may include other types of logic blocks and circuits in addition to those described herein.

As is well known in the art, the IOBs 106, the CLBs 104, and the programmable interconnect 108 may be configured to perform a variety of functions. Notably, the CLBs 104 are programmably connectable to each other, and to the IOBs 106, via the programmable interconnect 108. Each of the CLBs 104 may include one or more “slices” and programmable interconnect circuitry (not shown). Each CLB slice in turn includes various circuits, such as flip-flops, function generators (e.g., a look-up tables (LUTs)), logic gates, memory, and like type well-known circuits. The IOBs 106 are configured to provide input to, and receive output from, the CLBs 104.

Configuration information for the CLBs 104, the IOBs 106, and the programmable interconnect 108 is stored in the configuration memory 116. The configuration memory 116 may include static random access memory (SRAM) cells. The configuration logic 118 provides an interface to, and controls configuration of, the configuration memory 116. A configuration bitstream produced from the program memory 120 may be coupled to the configuration logic 118 through a configuration port 119. The configuration process of FPGA 102 is also well known in the art.

The I/O transceiver circuitry 122 may be configured for communication over any of a variety of media, such as wired, wireless, and photonic, whether analog or digital. The

I/O transceiver circuitry **122** may comprise gigabit or multi-gigabit transceivers (MGTs). The DCM blocks **112** provide well-known clock management circuits for managing clock signals within the FPGA **102**, such as delay lock loop (DLL) circuits and multiply/divide/de-skew clock circuits.

The processor block **114** comprises a microprocessor core, as well as associated control logic. Notably, such a microprocessor core may include embedded hardware or embedded-firmware or a combination thereof for a “hard” or “soft” microprocessor. A soft microprocessor may be implemented using the programmable logic of the FPGA **102** (e.g., CLBs **104**, IOBs **106**). For example, a Microblaze™ soft microprocessor, available from Xilinx® of San Jose, Calif., may be employed. A hard microprocessor may be implemented using an IBM Power PC, Intel Pentium, AMD Athlon, or like type processor core known in the art.

The processor block **114** is coupled to the programmable logic of the FPGA **102** in a well known manner. For purposes of clarity by example, the FPGA **102** is illustrated with 12 CLBS, 16 IOBs, 4 BRAMS, 4 DCMS, and one processor block. Those skilled in the art will appreciate that actual FPGAs may include one or more of such components in any number of different ratios. For example, the FPGA **102** may be selected from the Virtex™-II Pro family of products, commercially available from Xilinx® of San Jose, Calif.

One or more aspects of the invention include design tools for designing MP systems, memory systems, and multi-threading systems. Such design tools may be implemented using a computer. Notably, FIG. **17** is a block diagram depicting an exemplary embodiment of a computer **1700** suitable for implementing processes, methods, and design tool sections described herein. The computer **1700** includes a central processing unit (CPU) **1701**, a memory **1703**, various support circuits **1704**, and an I/O interface **1702**. The CPU **1701** may be any type of microprocessor known in the art. The support circuits **1704** for the CPU **1701** include conventional cache, power supplies, clock circuits, data registers, I/O interfaces, and the like. The I/O interface **1702** may be directly coupled to the memory **1703** or coupled through the CPU **1701**. The I/O interface **1702** may be coupled to various input devices **1712** and output devices **1711**, such as a conventional keyboard, mouse, printer, display, and the like.

The memory **1703** may store all or portions of one or more programs and/or data to implement the processes, methods, and design tool sections described herein. Although one or more aspects of the invention are disclosed as being implemented as a computer executing a software program, those skilled in the art will appreciate that the invention may be implemented in hardware, software, or a combination of hardware and software. Such implementations may include a number of processors independently executing various programs and dedicated hardware, such as ASICs.

The computer **1700** may be programmed with an operating system, which may be OS/2, Java Virtual Machine, Linux, Solaris, Unix, Windows, Windows95, Windows98, Windows NT, and Windows2000, WindowsME, and WindowsXP, among other known platforms. At least a portion of an operating system may be disposed in the memory **1703**. The memory **1703** may include one or more of the following random access memory, read only memory, magneto-resistive read/write memory, optical read/write memory, cache memory, magnetic read/write memory, and the like, as well as signal-bearing media as described below.

An aspect of the invention is implemented as a program product for use with a computer system. Program(s) of the program product defines functions of embodiments and can be contained on a variety of signal-bearing media, which include, but are not limited to: (i) information permanently stored on non-writable storage media (e.g., read-only memory devices within a computer such as CD-ROM or DVD-ROM disks readable by a CD-ROM drive or a DVD drive); (ii) alterable information stored on writable storage media (e.g., floppy disks within a diskette drive or hard-disk drive or read/writable CD or read/writable DVD); or (iii) information conveyed to a computer by a communications medium, such as through a computer or telephone network, including wireless communications. The latter embodiment specifically includes information downloaded from the Internet and other networks. Such signal-bearing media, when carrying computer-readable instructions that direct functions of the invention, represent embodiments of the invention.

Soft Platform

FIG. **2** is a block diagram depicting an exemplary embodiment of a design tool **200** for designing an MP system for implementation using an FPGA. The design tool **200** comprises an input section **202**, a soft platform section **204**, and an FPGA design tool section **206**. Briefly stated, the soft platform section **204** provides a configurable and programmable soft platform architecture for implementing MP systems. An MP system implemented using the soft platform architecture is mapped onto an FPGA architecture to produce a physical circuit design. The MP system may be realized by configuring an FPGA **208** in accordance with the circuit design. Thus, the soft platform architecture provides a mapping between a logical, message-centric system design and a physical, interface-centric system implemented within the FPGA **208**.

Notably, the FPGA circuit design may be “interface-centric” in that the circuit design is driven by the behavior at the system interfaces, as opposed to the “processor-centric” model, where the circuit design is driven by the behavior of an embedded processor. The interface-centric circuit design model matches well with the message-centric style of the soft platform architecture. Placement and usage of interfaces, memories, and their interconnections dominate the allocation of FPGA architecture features, and then allocation of functional elements (e.g., programmable logic, embedded processors) for the process components follow as a derivative.

More specifically, the input section **202** is coupled to one or more input devices **210** and a database storing an application programming interface (API) (“API database **212**”). The API database **212** includes a set of primitives associated with structural and behavioral attributes of the soft platform architecture. Thus, the API provides a “programming interface” for the soft platform architecture. An exemplary embodiment of a programming interface for a soft platform architecture is described below in the section entitled “PROGRAMMING INTERFACE.” Using the input devices **210**, a designer may interact with the input section **202** to produce specification data for an MP system or subsystem if the MP circuit is part of a larger system (hereinafter referred to as an “MP system”).

Notably, in one embodiment, a designer may use the primitives in the API database **212** directly to produce the MP system specification data for the soft platform architecture. In another embodiment, a designer may design the MP system using alternate constructions provided by the input

section **202**. That is, the input section **202** may comprise a design entry tool specific to the MP domain. Examples of such MP-specific design-entry tools include Click (available from The Massachusetts Institute of Technology), Rave (available from Cloudshield™ of Sunnyvale, Calif.), and SDL (a telecom standard from ITU-T). The input section **202** may then map the MP system specified using the alternate constructions onto the primitives in the API database **212** for the soft platform architecture. Thus, the input section **202** may provide a different level of abstraction than that provided by the soft platform architecture.

In one embodiment of the invention, the MP system specification data may comprise program code for programmatically interacting with the soft platform section **204**. The program code may be callable by an external design tool of the input section **202**. In another embodiment, the MP system specification data may comprise interpretive descriptions (e.g., descriptions in a textual or binary format) that the soft platform section **204** may interpret (e.g., an XML format). In either embodiment, the MP system specification is used to configure the soft platform architecture.

The soft platform section **204** is coupled to the input section **202** for receiving the MP system specification data. The soft platform section **204** is also coupled to a database storing the features or attributes of the soft platform architecture (“soft platform database **216**”), and a database storing features or attributes of the architecture of the FPGA **208** (“FPGA database **218**”).

The soft platform section **204** includes a first portion **203** for generating a logical description or “logical view” of an MP system in accordance with the MP system specification. The logical view is defined in terms of the logical components of the soft platform architecture stored in the soft platform database **216**. The soft platform section **204** includes a second portion **205** for generating a physical view of the MP system. Notably, using information in the FPGA database **218**, the soft platform section **204** maps the logical view of the MP system defined in terms of the soft platform architecture onto the architecture of the FPGA **208**. The soft platform section **204** provides FPGA design data as output, which represents a “physical view” of the MP system in terms of the architecture of the FPGA **208**. Details of the soft platform architecture are described below with respect to FIG. 4.

The FPGA design tools section **206** is coupled to the soft platform section **204** for receiving the FPGA design data. The FPGA design data may comprise a physical description of the MP system specified by the designer in terms of the components and features of the FPGA **208**. For example, in one embodiment, the FPGA design data may comprise a hardware description language (HDL) representation of the MP system design (e.g., Very high-speed integrated circuit description language (VHDL) or Verilog). The FPGA design tools section **206** processes the FPGA design data to produce configuration bitstream data. For example, the FPGA design tools section **206** may comprise various well-known FPGA design tools, such as a synthesis tool, a map/place/route tool, like-type tools known in the art. The FPGA design tools section **206** provides configuration bitstream data as output, which may be loaded into the FPGA **208**.

FIG. 3 is a flow diagram depicting an exemplary embodiment of a process **300** for designing an MP system for implementation using FPGA. The process **300** may be performed by the design tool **200** shown in FIG. 2. The process **300** begins at step **302**. At step **304**, an MP system specification is defined using an API associated with a soft platform architecture. The MP system specification specifies

attributes of an MP system, such as processing operations and memory attributes. As described above, the API may be programmatic (e.g., software function calls) or interpretive (e.g., XML).

At step **306**, a logical view of the MP system is generated in accordance with the MP system specification. As described above, the logical view of the MP system is defined in terms of a soft platform architecture. The logical components of the soft platform architecture are configured in accordance with the MP system specification to generate the logical view of the MP system. The term “logical components” refers to both the structural and behavioral attributes of the soft platform architecture, described in more detail below.

At step **308**, the logical view of the MP system is mapped onto an FPGA architecture to produce FPGA design data. That is, the logical components comprising the logical view are linked to physical components of an FPGA and, optionally, other devices connected to the FPGA (e.g., external memories). In one embodiment of the invention, the FPGA design data comprises an HDL representation of the MP system design. As described above, the FPGA design data provides a physical view of the specified MP system in terms of the architecture of the FPGA. That is, FPGA design data corresponds to the physical implementation of the logical view of the MP system on an FPGA device.

At step **310**, the FPGA system design is processed to produce configuration bitstream data. For example, if the FPGA system design comprises an HDL representation of the MP system design, the FPGA system design may be synthesized, mapped, placed, and routed in a well-known manner to produce bitstream data for configuring an FPGA. At step **312**, the configuration bitstream data is loaded into an FPGA to realize the MP system specified at step **304**. The process **300** ends at step **314**.

FIG. 4 is a block diagram depicting an exemplary embodiment of a soft platform architecture **400** in accordance with one or more aspects of the invention. The soft platform architecture **400** comprises a messages in system (MIS) component **402**, a process component **403**, and a stored system state (SSS) component **410**. The MIS component **402**, the process component **403**, and the SSS component **410** are logical components with no implied physical implementations. The physical implementations of the MIS component **402**, the process component **403**, and the SSS component **410** may be programmable, static, or partially programmable and partially static. The programmable portion of any of the MIS component **402**, the process component **403**, and the SSS component **410** may be conveyed via API primitives that define specification data generated by a designer.

Notably, the soft platform architecture **400** includes a programming/control interface **414** and a debug/test/monitor interface **416**. The programming/control interface **414** conveys the data for configuring the programmable portions of the soft platform architecture **400**. The programming/control information conveyed via the programming/control interface **414** comprises the structural and behavioral information related to the MIS component **402**, the process component **403**, and the SSS component **410**. An exemplary embodiment of a programming interface to the soft platform architecture **400** is described below in the section entitled “PROGRAMMING INTERFACE.” The debug/test/monitor interface **416** may be used during the design and implementation of an MP system defined in terms of the soft platform

architecture **400**. The interfaces **414** and **416** are illustrative, as there may be a single shared interface, or more than two interfaces.

The MIS component **402** is the logical storage point for all messages currently within the system implemented using the soft platform architecture **400**. The MIS component **402** includes an interface **412** to the enclosing environment **450** allowing for the input and output of messages. For example, the soft platform architecture **400** may be configured to produce an internet protocol (IP) packet router. The MIS component **402** may be configured to store all IP packets currently in flight through the router. The interface **412** may be one or more ports by which the router is connected to a physical network.

The MIS component **402** may be physically implemented using a centralized memory device, a plurality of distributed memory devices, or a combination thereof. In addition, the types, sizes, and interconnections of the physical memory elements, as well as the interface to such physical memory elements, are programmable through configuration of the MIS component **402**. An exemplary embodiment of a logical memory configuration that may be used as the MIS component **402** is described below in the section entitled "MEMORY MODEL."

The process component **403** comprises one or more processes that may be classified as fine grain operations processes (FOPs) **404**, coarse grain operations processes (COPs) **406**, or perimeter interface processes (PIPs) **408**. In addition, the process component **403** includes an inter-process synchronization component **418**. The FOPs **404**, COPs **406**, and PIPs **408** operate on messages stored within the MIS component **402**. The term "process," as used herein, denotes a concurrent agent for operating on information stored within the MIS component **402**. The term "thread" is used to denote an instance of a process.

Notably, each single execution of a process within the process component **403** is associated with a message stored in the MIS component **402** through a message context **405**. A process in the process component **403** may be physically implemented directly in programmable logic of an FPGA, or in a soft or hard embedded processor of an FPGA. In one embodiment of the invention, the message context **405** may be implemented using a data counter (DC) component **407**. The DC component **407** points to the current position in the current message being operated on by a particular process in the process component **403**. As the process executes, the DC component **407** may be updated, either automatically to advance to the next position in a message, or by execution of programmed "data jumps." In essence, the process moves over the message. The DC component **407** may be physically implemented using a memory element within the FPGA capable of storing an address associated with the location of a message in the memory of the MIS component **402**. Depending on the memory organization of the MIS component **402**, the DC component **407** may be a register, a BRAM, or an external RAM.

The processes of the process component **403** include a common interface. The inter-process communication component **418** may utilize the common interface to allow interaction between processes of the process component **403**. Such interactions may include, for example, creating or destroying a process or passing data to another process. The inter-process communication component **418** provides for a control flow in the processing of a message. At a microscopic level, the inter-process communication component **418** is capable of providing a control flow within a single process's execution. At a macroscopic level, the inter-

process communication component **418** is capable of providing a control flow from one process's execution to another process's execution. An exemplary embodiment of a multithread model that may be used as the inter-process communication component **418** is described below in the section entitled "MULTITHREAD MODEL."

A FOP **404** is the basic programmable unit for message processing. A FOP **404** performs a sequence of steps on a message stored within the MIS component **402**. At each step, a set of concurrent operations are performed. A FOP **404** may be associated with a DC component **407**. After each step, the DC component **407** may be incremented, or a data jump operation performed, such that the FOP **404** accesses a new portion of the message. The steps, as well as the operations performed during each step, may be programmable, static, or partially programmable and partially static in their definition. Examples of operations include, inspecting a field (e.g., a 16-bit header field) of a message, or performing simple arithmetic (e.g., adding one to a 16-bit header field) on a message.

A FOP **404** may be implemented within an FPGA using programmable logic. For example, a FOP may be implemented as a finite state machine (FSM) configured within the programmable logic of the FPGA. Alternatively, a FOP may be implemented on an embedded processor within an FPGA. For example, a FOP may be implemented as an operating system thread executed by the embedded processor. The physical implementation of a FOP **404** may be programmable, static, or partially programmable and partially static in its definition.

A COP **406** is used to incorporate a function block to perform a message processing operation. A function block may comprise a circuit or subsystem defined outside the context of the soft platform architecture **400**. For example, the function block may comprise a reusable intellectual property (IP) core for an FPGA. A COP **406** provides a programmable adapter between the interface of the function block and the common interface of the process component **403**. A COP **406** may be started, stopped, or interrupted by another process of the process component **403**.

A COP **406** may be defined statically and be in existence permanently. Alternatively, a COP **406** may be created and destroyed dynamically to allow dynamic reconfiguration of the function blocks associated therewith. For example, a COP **406** may be used to incorporate a function block for compression or encryption of all or part of a message stored in the MIS component **402**. A COP **406** may be associated with a DC component **407**, which points to the beginning of the message in the MIS component **402** to be processed by the COP **406**.

A PIP **408** is concerned with enabling the movement of a message to and from soft platform architecture **400**. In one embodiment of the invention, a PIP **408** may be used to incorporate a function block, similar to a COP **406**. The function block associated with a PIP **408** may comprise a circuit or subsystem defined outside the context of the soft platform architecture **400** that is specifically geared to perform I/O functions. In another embodiment of the invention, a PIP **408** may be implemented as a FSM in programmable logic of the FPGA.

For example, a PIP may be used to receive or transmit successive words of a message over an interface using a protocol defined for the interface. For example, a PIP may act as a smart adapter for the Xilinx® LocalLink interface to a networking core or the interface to a Gigabit MAC core. A PIP may also communicate with other system components implemented within the FPGA.

The SSS component **410** may be used to store state information associated with the processes of the process component **403**. For example, the SSS component **410** may be used to store a message context **405** for a FOP **404**. The SSS component **410** may be physically implemented using a centralized memory device, a plurality of distributed memory devices, or a combination thereof.

Memory Model

FIG. **5** is a block diagram depicting an exemplary embodiment of a design tool **500** for designing a memory subsystem for implementation using an FPGA. The design tool **500** comprises an input section **502** and a memory model section **504**. The memory model section **504** provides a configurable and programmable memory model for implementing a memory subsystem using an FPGA and, optionally, other memories connected to an FPGA.

In particular, the input section **502** is coupled to a database that stores an API associated with the memory model, referred to herein as the memory interconnection description language (MIDL) library **506**. The MIDL library **506** comprises a set of primitives for defining structural and behavioral attributes of the memory model. Thus, the MIDL library **506** provides a programming interface for the memory model. A designer may interact with the input section **502** to produce specification data for a memory subsystem. The designer may work directly with the MIDL library **506**, or may work indirectly with the MIDL library **506** through an alternative design tool defined within the input section **502**. The memory subsystem specification data may be programmatic or may be interpretive (e.g., XML). An example of an MIDL specification for a 32-bit wide memory constructed from two 16-bit wide memories, which are in turn mapped to physical BRAM in an FPGA, is shown in Appendix A.

The memory model section **504** is coupled to the input section **502** for receiving the memory model specification. The memory model section **504** is also coupled to a database that stores the features or attributes of the memory model (“memory model database **508**”), and a database that stores the memory attributes of an FPGA and external memories associated therewith (“FPGA memory database **510**”). The memory model section **504** includes a first portion **503** for generating a logical view of a memory subsystem in accordance with the memory subsystem specification. The logical view is defined in terms of the logical components of the memory model stored in the memory model database **508**.

The memory model section **504** may include an analysis/optimization portion **512** for analyzing and optimizing the logical view of the memory subsystem in accordance with constraint data provided by a designer. The memory model section **504** further includes a second portion **505** for generating a physical view of the memory system based on the logical view. Notably, using information in the FPGA memory database **510**, the memory model section maps the logical view of the memory subsystem onto the physical memory components associated with an FPGA. The memory model section **504** provides FPGA design data as output.

FIG. **6** is a block diagram depicting an exemplary embodiment of a memory model **600** in accordance with one or more aspects of the invention. The memory model **600** comprises a memory element **602** having a memory interface **604** and a memory interconnection interface **606**. The memory element **602** is a logical component with no implied physical implementation. That is, the memory element **602** may comprise one or more physical memories, disposed

within an FPGA and/or external thereto. The memory interface **604** is configured to provide communication between the memory element **602** and a computational element **608** (e.g., one or more threads). For example, the memory element **602** may be configured to store messages, and the computational element may access the messages through the memory interface **604** for processing. The memory interconnection interface **606** is configured to provide communication between the memory element **602** and an interconnection **610**. The interconnection **610** may comprise a portal to an I/O interface (e.g., a Gigabit Ethernet MAC core on the FPGA) or to another memory element (either within the FPGA or external to the FPGA). For example, the memory element **602** may be configured to store messages, and the interconnection may receive and transmit messages to and from the memory-interconnection interface **606**.

The memory model **600** is characterized by a “memory architecture” and a “memory-interconnection architecture.” The memory architecture pertains to the size, type, and topology of one or more memory circuits comprising the memory element **602**. The memory-interconnection architecture pertains to the type, bus width (e.g., number of wires), and topology of interconnection (e.g., crossbar) of the one or more memory circuits comprising the memory element **602**. In general, with respect to the memory model **600**, the term “interface” imparts knowledge related to the protocols that must be adhered to for the particular interaction, whereas the term “architecture” imparts knowledge related to the critical path that particular data follows within the memory model **600**.

The memory and interconnection architectures of the memory model **600** may be defined by the physical location of the memory circuits used to implement the model, as well as the logical configuration of the interface to such memory circuits. For example, the memory may be physically centralized (i.e., a single physical memory circuit), or several memory circuits may be physically distributed. The memory circuit(s) used to implement the memory model **600** may be disposed within the FPGA (e.g., any combination of on-chip BRAMs, LUT-based RAMs, and shift registers), disposed external to the FPGA (e.g., external SDRAMs, DDR SDRAMs, and RDRAMs), or a combination thereof. In addition, the interface to such memory circuit(s) may be logically centralized (e.g., a unified programming interface) or logically distributed (e.g., multiple logical interfaces).

In light of the various physical and logical configurations for the memory and interconnection architectures, various logical schemes for storing messages may be implemented using the memory model **600**. In one embodiment, all messages may be stored within a single memory (e.g., a queue of messages in a memory) (“uniform message storage”). Alternatively, different messages may be allocated over different memories (“interleaved message storage”). In yet another alternative, each message may be physically allocated over different memories (“striped message storage”). In another embodiment, each message may be logically allocated over different memories (“separated message storage”). FIGS. **9** and **10** depict examples of memory subsystems illustrating exemplary configurations for the memory and interconnection architectures with respect to the storage of messages in a system. Those skilled in the art will appreciate that many other configurations for the memory and interconnection architectures may be employed in accordance with the above attributes, of which FIGS. **9** and **10** are examples.

In particular, FIG. **9** is a block diagram depicting an exemplary embodiment of a memory subsystem **900** that

may be implemented using the memory model **600**. The memory subsystem **900** illustratively comprises a set of BRAMs **902₁** through **902_N**, where N is an integer greater than one (collectively referred to as BRAMs **902**). The BRAMs **902** may be disposed within an FPGA. Each of the BRAMs **902** includes a memory interface **904**. The memory interface **904** of each of the BRAMs **902** is configured for communication with a computational element **906**. For example, each of the computational elements **906** may comprise an instance of a process (e.g., a thread) within the soft platform architecture described above. Each of the BRAMs **902** includes a second interface for receiving incoming message data.

Notably, an incoming message may be “striped” across the BRAMs **902** such that each of the BRAMs **902** stores only a portion of the incoming message. Each of the computational elements **906** may then access respective ones of the BRAMs **902** through the respective memory interface **904** to access a portion of the incoming message. The memory subsystem **900** is an example of striped message storage using physically distributed memories within an FPGA.

FIG. **10** is a block diagram depicting another exemplary embodiment of a memory subsystem **1000** that may be implemented using the memory model **600**. The memory subsystem **1000** illustratively comprises a set of BRAMs **1002₁** through **1002_N**, where N is an integer greater than one (collectively referred to as BRAMs **1002**). The BRAMs **1002** may be disposed within an FPGA. Each of the BRAMs **1002** includes an interface in communication with a memory interface **1004**. The memory interface **1004** includes an interface in communication with a plurality of computational elements **1006**. The memory interface **1004** also includes an interface for receiving incoming message data.

The BRAMs **1002** are logically part of one centralized memory with a dedicated memory interface **1004** that manages access to the messages stored in the BRAMs **1002**. Each of the computational elements **1006** may access a message or portion thereof through the memory interface **1004**. The memory subsystem **1000** is an example of a logically centralized, physically distributed memory organization.

Returning to FIG. **6**, the memory and interconnection interfaces in the memory model **600** may be defined in accordance with various configurable attributes, such as the number of ports to a memory and the width of each port. In addition, the memory model **600** may be configured to provide a reactive memory subsystem, such as a cooperative memory subsystem.

Notably, FIG. **11** is a block diagram depicting an exemplary embodiment of a cooperative memory interface **1100** that may be implemented using the memory model **600**. Cooperative memories are memories that do not just stall or block when data is not available, but rather respond back with a message, such as “data will be available in three cycles.” As shown, the memory element **602** comprises a memory **1102**, control logic **1104**, and interface logic **1106**. The interface logic **1106** is coupled to the computational element **608** via a data bus **1108**, a control bus **1110**, and a status bus **1112**. The data bus **1108** has a width of n, the control bus **1110** has a width of m, and the status bus **1112** has a width of k. In general, the width of the control bus **1110** and the width of the status bus **1112** will be much less than the width of the data base **1108**. For purposes of clarity by example, the data bus **1108**, the control bus **1110**, and the status bus **1112** are shown as separate buses. It is to be understood, however, that the data bus **1108**, the control bus

1110, or the status bus **1112**, or any combination thereof, may be multiplexed within the interface logic **1106** over the same physical bus.

The computational element **608** requests data using the control bus **1110**. The control logic **1104** determines whether the data is available within the memory **1102**. If so, the data is communicated to the computational element **608** over the data bus **1108**. Otherwise, the control logic **1104** generates a status signal for communication to the computational element **608** over the status bus **1112**. The status signal may indicate the unavailability of the requested data and an estimated duration after which the data will be available.

FIG. **7** is a flow diagram depicting an exemplary embodiment of a process **700** for designing a memory subsystem for implementation using an FPGA. The process **700** is described with respect to the memory model **600** of FIG. **6**. The process **700** begins at step **702**. At step **704**, a memory subsystem specification is defined using a MIDL. As described above, the MIDL comprises a set of primitives associated with the logical memory model **600**. Notably, the MIDL includes primitives for defining the memory architecture, the memory-interconnection architecture, the memory interface, and the memory-interconnection interface.

At step **706**, a logical view of the memory subsystem is generated in accordance with the memory subsystem specification. The logical view is defined in terms of the memory model **600**. That is, the logical components of the memory model **600** are configured in accordance with the memory subsystem specification to generate a logical view of the memory subsystem.

At step **707**, the memory subsystem may be analyzed and optimized in accordance with predefined constraint and test data. The constraint data may include constraints on memory access, time, and interconnect resources. The test data may include one or more test memory access patterns. In one embodiment of the invention, an analysis model based on memory access, time, and interconnect resources is employed.

Notably, FIG. **8** is a graph **800** illustrating an exemplary embodiment of a memory analysis model. The graph **800** includes an axis **802** representing abstract memory addresses, an axis **804** representing abstract time, and an axis **806** representing interconnect resources. The graph **800** depicts an exemplary access pattern comprising a plurality of points **808**. Each point **808** signifies a memory access corresponding to a particular memory location (address) at a particular time that utilizes a particular interconnect resource. For example, the exemplary access pattern may result from a burst of packets entering the memory subsystem, followed by some header manipulation, and a burst of packets exiting the memory subsystem. The predefined constraint data is shown superimposed over the graph **800** as a cuboid **810**. If all points **808** are within the cuboid **810**, the access pattern is valid. Otherwise, an optimization is required to satisfy the constraints.

Returning to FIG. **7**, at step **708**, the logical view of the memory subsystem is mapped onto an FPGA architecture to produce FPGA design data. That is, the logical components comprising the logical view are linked to physical memory components of an FPGA and, optionally, other memory devices connected to the FPGA. The FPGA design data provides a physical view of the specified memory subsystem in terms of the memory architecture of the FPGA. That is, FPGA design data corresponds to the physical implementation of the logical view of the memory subsystem defined

using the MIDL. In one embodiment of the invention, the FPGA design data comprises an HDL representation of the MP system design.

At step 710, the FPGA design data may be combined with other FPGA design data to define a system. For example, the memory subsystem may be incorporated into an MP system designed as described above in the section entitled "SOFT PLATFORM." That is, the memory subsystem may be the implementation of the MIS component of the soft platform architecture used to implement an MP system.

At step 712, the combined FPGA design data is processed to produce configuration bitstream data. For example, if the combined FPGA design data comprises an HDL representation, the FPGA design data may be synthesized, mapped, placed, and routed in a well-known manner to produce bitstream data for configuring an FPGA. At step 716, the configuration bitstream data is loaded into an FPGA. The process 700 ends at step 718.

Multithread Model

FIG. 12 is a block diagram depicting an exemplary embodiment of a design tool 1200 for designing a multithread model for implementation using an FPGA. The design tool 1200 comprises an input section 1202 and a multithread model section 1204. The multithread model section 1204 provides a configurable and programmable multithread model for implementing multiple threads using an FPGA. As used herein, the term "thread" is a concurrent execution unit appropriate for implementing a process, such as some of the processes described above with respect to the soft platform architecture (e.g., FOPs and PIPs). The multithread model employs a synchronization mechanism for controlling the various threads thereof and, in some embodiments, passing data therebetween.

In particular, the input section 1202 is coupled to a database that stores a library of multithreading primitives ("multithread primitive database 1206"). The multithread primitive database 1206 stores a set of primitives for defining structural and behavioral attributes of the multithread model. Thus, the multithread primitive database 1206 provides a programming interface for the multithread model. Notably, the multithread primitive database 1206 includes primitives for starting a thread, stopping a thread, suspending a thread, as well as synchronization of such starting, stopping, and suspending among threads. In addition, primitives are provided for indicating status information for individual threads, such as completion or suspension, among other threads. Furthermore, primitives may be provided for allowing data communication among threads.

A designer may interact with the input section 1202 to produce specification data for a multithreading system. The designer may work directly with the multithread primitive database 1206, or may work indirectly with the multithread primitive database 1206 through an alternative design tool defined within the input section 1202. The multithreading system specification data may be programmatic or may be interpretive (e.g., XML).

The multithread model section 1204 is coupled to the input section 1202 for receiving the multithreading system specification data. The multithread model section 1204 is also coupled to a database that stores the features or attributes of the multithread model ("multithread model database 1208"), and a database that stores the physical attributes of an FPGA ("FPGA database 1210"). The multithread model section 1204 includes a first section 1203 for generating a logical view of the multithreading system in accordance with the multithreading system specification.

The logical view is defined in terms of the logical components of the multithread model stored in the multithread database 1208. The multithread model section 1204 includes a second portion 1205 for generating a physical view of the multithreading system based on the logical view. Notably, using information in the FPGA database 1210, the multithread model section 1204 maps the logical view of the multithreading system onto the physical components associated with an FPGA. The multithread model section 1204 provides FPGA design data as output.

FIG. 13 is a block diagram depicting an exemplary embodiment of a thread model 1300 in accordance with one or more aspects of the invention. The thread model 1300 comprises a thread 1302 having a start terminal 1304, a stop terminal 1306, a suspend terminal 1308, a clock terminal 1310, an is Finished terminal 1312, and an isSuspended terminal 1314. The start terminal 1304, the stop terminal 1306, and the suspend terminal 1308 comprise an input bus of the thread 1302 for controlling operation thereof. The is Finished terminal 1312 and the isSuspended terminal 1314 comprise an output bus of the thread 1302 for conveying status information related to the thread 1302. As described below, the output bus of the thread 1302 may include other portions for communicating signals amongst threads. The thread model 1300 is a logical component with no implied physical implementation. An example interface in VHDL for a thread is shown in Appendix B.

Notably, the thread model 1300 may be physically implemented in programmable logic of an FPGA as a synchronous FSM. That is, a clock drives the state machine's transitions and, within each state of the state machine, operations are performed on operands producing outputs. In another embodiment, the thread model 1300 may be implemented using a microcontroller embedded within an FPGA. In yet another embodiment, the thread model 1300 may be implemented using a hard or soft microprocessor embedded within an FPGA.

The thread 1302 includes control logic 1320 for processing data and producing control state data 1316 and operation state data 1318. The control state data 1316 captures the state of the thread 1302 in terms of inter-thread communication (e.g., the thread is finished or suspended). The operation state data 1318 captures the internal state of the thread 1302, which is defined in accordance with the operation of the control logic 1320.

In one embodiment of the invention, the thread 1302 includes an IDLE control state that corresponds to the thread 1302 not currently carrying out any operation. During the IDLE control state, the is Finished terminal 1312 is asserted to indicate that the thread 1302 is not doing any work. If the start terminal 1304 is asserted, the thread 1302 moves out of the IDLE control state and performs the various operations that the thread 1302 is configured to perform. The isFinished terminal 1312 is no longer asserted to indicate that the thread 1302 is in operation. Asserting the stop terminal 1306 returns the thread 1302 to the IDLE control state, terminating all operations. Asserting the suspend terminal 1308 causes the thread 1302 to remain in its current operation state, regardless of how many clock cycles occur on the clock terminal 1310. The suspend terminal 1308 may be used during debugging or testing through an external agent. The isSuspended terminal 1314 is asserted while the thread 1302 is suspended.

The operation state data 1318 depends on the operational configuration of the control logic 1320 of the thread 1302 in accordance with specification data provided by a designer. That is, the control logic 1320 of the thread 1302 is

17

configured to execute a series of steps, where one or more operations are performed at each step. In one embodiment, the thread 1302 may be designed to have one or more designated terminal operation states that cause the thread 1302 to enter the IDLE control state and assert the is Finished terminal 1312. Alternatively, there may be no such designated terminal control states, in which case the thread is control externally by asserting the stop signal.

For example, a VHDL code fragment for implementing the thread 1302 may be:

```
update: process (clk, stopThread)
```

```
begin—process update
```

```
  if stopThread='1' then
```

```
    state<=idle;
```

```
  elsif clk'event and clk='1' and suspendThread='0' then
```

```
    state<=nextState;
```

```
  end if;
```

```
end process update;
```

where the thread 1302 is implemented as a state machine. In this example, the IDLE control state is implemented as an extra state added to the internal operation state set of the thread. While there is no explicit suspend control state, the suspend mechanism may be implemented by driving the suspend terminal 1308 to prevent the calculated nextState from being latched into the state machine's register. Thus, the thread will remain in the current operation state, with no forward progress. For purposes of clarity by example, the implications for the values of outputs from the state are not shown explicitly in the above exemplary VHDL code fragment.

The thread 1302 has thus far been described with respect to an external agent that asserts the start, stop, and suspend terminals. The “external agent” may be another thread, thus allowing threads to control other threads. In order to enable one thread to write or read the signals of another thread, the multithread model employs an interconnection topology and an addressing mechanism. That is, a plurality of threads are interconnected for communication amongst themselves, and a thread may associate the address of another thread with its collection of input and output signals.

Notably, FIG. 14 is a block diagram depicting an exemplary embodiment of a multithread model 1400 in accordance with one or more aspects of the invention. The multithread model 1400 comprises a set of thread models 1402₁ through 1402_N, where N is an integer greater than one (collectively referred to as thread models 1402). The multithread model 1400 also includes an interconnection component 1404. Each of the thread models 1402 includes an input bus 1406 and an output bus 1408. The input bus 1406 and the output bus 1408 of each of the thread models 1402 are in communication with the interconnection component 1404. In one embodiment, the interconnection component 1404 facilitates complete point-to-point communication of control, status, and/or data among the thread models 1402.

In one embodiment of the invention, the output bus 1408 of a thread model 1402 comprises a start control bus 1410, a stop control bus 1412, a suspend control bus 1414, and a status bus 1416. The width of each of the start control bus 1410 and the stop control bus 1412 is N (i.e., the number of thread models 1402 in the multithread model 1400). The width of the suspend control bus 1414 may be N-1 if self-suspension of a thread is not defined. The status bus 1416 may comprise M status signals (e.g., isFinished and isSuspended signals) and thus the width of the status bus

18

1416 is M. The input bus 1406 of a thread model 1406 comprises a start terminal 1422, a stop terminal 1424, and a suspend terminal 1426.

In one embodiment of the invention, each of the thread models 1402 produces a control signal for each of the other thread models 1402 (e.g., thread model 1402₁ produces control signals for thread models 1402₂ through 1402_N) through operation of control logic 1430. Thus, if there are eight thread models 1402 in the multithread model 1400, then each thread model 1402 will produce eight start signals, eight stop signals, and seven suspend signals in accordance with the control logic 1430. For each of the thread models 1402, start signal and one stop signal is connected in a self-loop, which allows a thread model 1402 to start and stop itself. The interconnection component 1404 facilitates the connection between the output bus 1408 of a given thread model and the input buses of each of the other thread models.

FIG. 15 is a block diagram depicting an exemplary embodiment of a multithread system 1500 that may be implemented using the multithread model 1400. The multithread system 1500 illustratively comprises four threads 1502 through 1502₄ (collectively referred to as threads 1502) and a logical OR component 1504. The thread 1502₁ includes a start terminal 1506 for providing an input start signal to the thread 1502₁. An output of the OR component 1504 is coupled to the start terminal 1506. Each of the threads 1502 includes a start control terminal 1508 for providing output start control signals. Inputs of the OR component 1504 are coupled to the start control terminals 1508 of the threads 1502. Each of the threads 1502 includes control logic 1510 for controlling the assertion of their respective start control terminal 1508.

Notably, if it is not intended that a particular one of the threads 1502 control the starting of the thread 1502₁, then the start control terminal 1508 is not asserted. If one of the threads 1502 intends to start the thread 1502₁, the start control terminal 1508 of that thread is asserted. For example, if the thread 1502₃ intends to start the thread 1502₁, then the thread 1502₃ asserts its start control terminal 1508. The start control terminals 1508 are logically OR-ed together by the OR component 1504 such that if one or more is asserted, the thread 1502₁ will be started. For purposes of clarity by example, a synchronization mechanism for starting the thread 1502₁ is shown. It is to be understood, however, that the multithread system 1500 may be extended to start, stop, and suspend any number of threads.

Returning to FIG. 14, the output bus 1408 of a thread model 1402 may include a data bus 1428. Data may be communicated amongst the thread models 1402 through the interconnection component 1404. In one embodiment of the invention, the data bus 1428 may comprise a bus for each of the thread models 1402 in the multithread model 1400. For example, if the thread model 1402₁ intends to send data to the thread model 1402₂, then the thread model 1402₁ communicates the data over the bus associated with the thread model 1402₂. The validity of the data may be assured by timing, with each of the thread models 1402 designed such that the consumer of the data does not access the data until it has been written. Alternatively, a validity flag 1418 may be employed to indicate valid data.

In yet another embodiment, each of the thread models 1402 may include an identifier 1420 (e.g., a memory address). A pull mechanism may be employed to retrieve data from one thread model using another thread model. A thread model 1402 requiring data provides the identifier to the thread model 1402 in possession of the data, together

with a read request, and the data item is provided after some latency. In yet another embodiment, a push mechanism may be employed, whereby once a thread model 1402 has data, it pushes the data to all threads that are known to require the data, together with its identifier 1420.

Programming Interface

FIG. 16 is a block diagram depicting an exemplary embodiment of a programming interface 1600 for the soft platform architecture described above. The programming interface 1600 comprises an API 1602. The API 1602 comprises a set of primitives 1604 for configuring the soft platform architecture in accordance with a design specification. In one embodiment, the primitives of the API 1602 are programming instructions or program code (e.g., function calls) for interacting programmatically with the soft platform architecture. In another embodiment, the primitives of the API 1602 are interpretive instructions that may be interpreted by the soft platform architecture. For example, a textual representation may be used to convey the design specification data to the soft platform architecture, such as XML. As is well-known in the art, XML exhibits a standardized format and a number of available parsers. The document type definition (DTD) is a formal grammar to specify the structure and permissible values in the XML document. Thus, the API 1602 may include a defined DTD that is specific to the various programmable features of the soft platform architecture.

In one embodiment of the invention, the set of primitives 1604 comprises FOP primitives 1606, COP primitives 1608, PIP primitives 1610, signal grouping primitives 1612, inter-process communication primitives 1614, memory element primitives 1616, run-time primitives 1618, implementation metric primitives 1620, and debugging primitives 1622. Each of the aforementioned primitives is discussed in detail below.

The FOP primitives 1606 provide a coding environment targeting multiple threads that operate in parallel. The FOP primitives 1606 include instruction set primitives 1624 and physical implementation primitives 1626. The instruction set primitives 1624 are used to program the threads. That is, the instruction set primitives 1624 provide a mechanism for establishing an instruction set of a thread, where the instruction set itself is programmable. Thus, a designer may modify an instruction set for a thread as desired (e.g., providing a domain-specific set of instructions). The physical implementation primitives 1626 are used to define the physical implementation of a given thread. For example, a thread may be implemented in programmable logic of an FPGA or in a hard or soft microprocessor or using a microcontroller.

In one embodiment, each thread is implemented as a custom FSM in programmable logic of an FPGA. An instruction set is defined for the FSM thread, where each instruction has a dedicated implementation. There is no additional support required for unused operations in the instruction set and multiple instructions may be executed simultaneously.

The COP primitives 1608 are used to include a function block into the design. In one embodiment, the COP primitives 1608 comprise "include" type primitives for specifying a particular function block to include within the design.

The PIP primitives 1610 may comprise instruction set primitives 1628 and physical implementation primitives 1630. The instruction set primitives 1628 are used to define an instruction set for a thread in a similar manner to the FOP primitives 1606 described above. Unlike the FOP primitives 1606, however, the instruction set primitives 1628 may be

used to define certain system instructions. The system instructions are used to communicate with input/output interface logic blocks that communication with another system (within the FPGA or external thereto). For example, an interface logic block may be a gigabit Ethernet MAC core. The instruction set primitives 1628 provide support for different communication protocols to read/write data over various interfaces. For example, one type of interface may be completely streaming, with data arriving at every clock cycle. Another type of interface may have flow control, where there may be a pause in the data stream.

The physical implementation primitives 1630 define the physical implementation of the PIP (e.g., FSM, microprocessor). The PIP primitives 1610 may also comprise include type primitives for specifying the inclusion of the interface function block. Each interface block may have multiple ports, or groups of signals, associated therewith. One group of signals contains the connectivity to the external environment. The others connect to one or more PIP threads. For example, an interface block may have a set of signals that form a receive port and another set of signals that form a transmit port. In this case, the signals may be grouped together such that each port is assigned to a different PIP thread.

The signal grouping primitives 1612 are used to define signal groups. Grouping of signals may occur in various contexts, such as when connecting an interface block to a PIP thread, as described above, or when connecting to a memory element. In such cases, the programming information for an element such as a FOP thread states that the FOP thread is connected to another element.

The inter-process communication primitives 1614 provide support for synchronization and data communication between threads. Some basic aspects of the mechanism, such as support for starting, stopping, and suspending processes, may be built into the soft platform architecture. Thread synchronization and data communication, however, may be completely specified by a designer. In one embodiment, connections are explicitly specified between processes. Alternatively, required connections may be inferred from the operations defined for a particular group of processes. For example, an operation to start another process may have the form of "START(process)" or an operation to pass a data value to another process may have the form of "PASS(data, destination process)." With such an operation, a connection may be inferred without a designer explicitly defining the connection.

The memory element primitives 1616 are used to define the various types, sizes, and interconnections of memory elements. The memory element primitives 1616 may include the MIDL primitives discussed above in the section entitled "MEMORY MODEL," for specifying the logical view of a memory subsystem.

The run-time primitives 1618 may be used to apply run-time reconfiguration. Run-time reconfiguration involves the modification of a circuit implemented within an FPGA at run-time. Dynamic reconfiguration for an FPGA is well-known in the art. For example, the run-time primitives 1614 may be used to migrate functionality between programmable logic and an embedded processor. Initially, some functionality is implemented in programmable logic with other functionality implemented using an embedded microprocessor. Implicitly, the programmable logic implementation exhibits higher performance than the processor implementation. Functionality may be offloaded to the processor to save area within the programmable logic. During execution, statistics may be taken to give feedback on the chosen

partition. A reconfiguration controller determines a new partition and reconfigures the FPGA. An exemplary decision condition would be based on the frequency of events. More frequency events may thus be handled in programmable logic, with less frequency events handled by the embedded processor.

The implementation metric primitives **1620** may be used to define the requirements of the system. For example, the implementation metric primitives **1620** may be used to establish performance requirements that must be met. The implementation metric primitives **1620** may be used to create constraints files (e.g., timing constraint files) that can be used by FPGA design tools (e.g., map/place/route tools). The implementation metric primitives may also provide low-level optimizations (e.g., clock frequency requirements, throughput latency requirements), as well as high-level optimizations (e.g., optimize for area, throughput, latency, power, and the like).

The debugging primitives **1622** may be used to provide debugging capabilities. The debugging primitives **1622** may be used to capture simulated data associated with the soft platform architecture. For example, instead of presenting signal waveforms to the designer, the debugging primitives **1622** allow for data presentation in a more abstracted form. The debugging primitives **1622** also provide lower-level functions through the use of tags or commands that cause the circuitry to be modified and operate in a debug mode.

Appendix C shows exemplary XML code that defines interface logic for a logic block or “core,” referred to as “Aurora,” which may be used to drive the soft platform architecture described herein. The Aurora interface, available from Xilinx® of San Jose, Calif., is implemented as external intellectual property for point-to-point communication over multi-gigabit transceivers. The first set of signals (clk, reset, RXN, RXP, TXN, and TXP) represent the signals that connect to the external environment. In this example, the data lines would be tied to serial transceivers. The port labeled “rx” is the receive port and has several signals associated therewith. Similarly, the port labeled “tx” is the transmit port and also has several signals associated therewith.

Within each port is a clock associated therewith. The clock determines the clock domain. In the present example, both “rx” and “tx” ports have an output clock. Thus, the IP function block has circuitry to generate a clock signal. This clock would drive all threads in the determined clock domain. Alternatively, a “useclk” tag may be used if the IP block does not generate a clock signal. The clock that drives the port is also used to drive other threads in the clock domain.

Appendix D illustrates an exemplary XML code of a PIP thread that handles the receive-side connection to the Aurora interface defined in Appendix C. The PIP thread reads data from the receive port of the Aurora interface and stores the data in a buffer. The protocol for the interface includes flags marking the state of a frame, end of frame, and whether data is valid. The data valid (RXSourceReadyBar) signal allows the stream to pause. The PIP thread waits until the entire frame has been received before committing the frame to memory. Committing the frame to memory is an indicating mechanism informing the buffer that an entire frame is in memory. This ensures that other blocks of logic that read from the memory do not process a partial frame.

Line 2 of Appendix D illustrates that the PIP thread connects to the A port of a memory named “a2e_buf.” Line 3 of Appendix D shows that the PIP thread also connects to the rx port of the interface block named Aurora (as shown in

Appendix C). Lines 4–8 of Appendix D define the variables of the PIP thread. In the present example, only internal variables are shown, but variables may also be defined to connect to other threads.

Appendix E illustrates exemplary XML code for effecting an explicit connection. A thread named “sender” having an output named “myout” is defined. Threads named “receiver_1” and “receiver_2”, each with an input named “myin,” are also defined. The defined connection will connect the output of the sender thread with the two input ports of the receiver threads.

While the foregoing describes exemplary embodiment(s) in accordance with one or more aspects of the present invention, other and further embodiment(s) in accordance with the one or more aspects of the present invention may be devised without departing from the scope thereof, which is determined by the claim(s) that follow and equivalents thereof. Claim(s) listing steps do not imply any order of the steps. Trademarks are the property of their respective owners.

APPENDIX A

```

MEMORY top
{
  ARCHITECTURE
  {
    CONNECT MEMINTERFACE (Mem1), MEMICINTERFACE
    (top);
    CONNECT MEMINTERFACE (Mem2), MEMICINTERFACE
    (top);
  }
  MEMINTERFACE
  {
    PORT E(RW, 32);
    CONTROL { };
  }
  MEMICINTERFACE
  {
    PORT C(RW, 16);
    PORT D(RW, 16);
    CONTROL { };
  }
  MEMORY Mem1
  {
    ARCHITECTURE
    {
      TYPE BRAM;
      SIZE 18K;
    }
    MEMINTERFACE
    {
      PORT A(RW, 16);
      CONTROL { };
    }
    MEMICINTERFACE
    {
  }
  }
  MEMORY Mem2
  {
    ARCHITECTURE
    {
      TYPE BRAM;
      SIZE 18K;
    }
    MEMINTERFACE
    {
      PORT B(RW, 16);
      CONTROL { };
    }
    MEMICINTERFACE
    {
  }
  }
}

```

APPENDIX B

```
entity IPv4_handler is
generic (
TID: integer := IPv4_HANDLER_TID);
port (
clk: in std_logic;
-- Control for this thread
startThread: in std_logic;
stopThread: in std_logic;
suspendThread: in std_logic;
-- Status for this thread
threadIsBlocked: out std_logic;
threadIsFinished: out std_logic;
-- Control and status for other threads
isFinished: in std_logic_vector((NUM_THREADS - 1) downto
0);
start: out std_logic_vector((NUM_THREADS - 1)
downto 0);
stop: out std_logic_vector((NUM_THREADS - 1)
downto 0);
suspend: out std_logic_vector((NUM_THREADS - 2)
downto 0);
isBlocked: in std_logic_vector((NUM_THREADS - 1)
downto 0));
```

APPENDIX C

```
<hook name="aurora">
<!-- input clock -->
<clk name="clk"/>
<reset name="reset"/>
<input name="RXN" width="1"/>
<input name="RXP" width="1"/>
<output name="TXN" width="1"/>
<output name="TXP" width="1"/>
<port name="rx">
<!-- output clock -->
<clk name="rxclk"/>
<output name="RXdata"width="16" order="ascending"/>
<output name="RXrem" width="1"/>
<output name="RXstartofFrameBar" width="1"/>
<output name="RXendofFrameBar" width="1"/>
<output name="RXsourceReadyBar" width="1"/>
</port>
<port name="tx">
<!-- output clock -->
<clk name="txclk"/>
<input name="TXdata" width="16" order="ascending"/>
<input name="TXrem" width="1"/>
<input name="TXstartofFrameBar" width="1"default="1"/>
<input name="TXendofFrameBar" width="1"default="1"/>
<input name="TXsourceReadyBar" width="1"default="1"/>
<output name="TXdestReadyBar" width="1"/>
</port>
</hook>
```

APPENDIX D

```
1: <FSM name="aurora_rx_thread">
2: <usemem name="a2e_buf"port="a"/>
3: <usehook name="aurora"port="rx"/>
4: <variables>
5: <variable name="count"type="internal" width="16"/>
6: <variable name="writes"type="internal" width="16"/>
7: <variable name="myaddress"type="internal" width="16"/>
8: </variables>
9: <states start="startState">
10: <state name="startState">
11: <operation op="ASSIGN" params="count, 0"/>
12: <operation op="ASSIGN" params="writes, 0"/>
13: <operation op="ASSIGN" params="myaddress, 0"/>
14: <conditional>
15: <condition cond="EQUAL" params="RXstartof-
FrameBar, 0">
16: <transition next="getBody"/>
```

APPENDIX D-continued

```
17: </condition>
18: <condition cond="else" params="" >
19: <transition next="startState"/>
20: </condition>
21: </conditional>
22: </state>
23: <state name="getBody">
24: <conditional>
10 25: <condition cond="EQUAL" params="RXsource-
ReadyBar, 0">
26: <operation op="ADD" params="writes, writes,
1"/>
27: <operation op="ADD" params="myaddress,
myaddress, 1"/>
15 28: <operation op="WRITE_DATA" params=
"RXdata, myaddress [9:01]"/>
29: <conditional>
30: <condition cond="EQUAL"
params="RXendofFrameBar, 1">
31: <operation op="ADD" params="count,
count, 2"/>
20 32: </condition>
33: <condition cond="else" params="" >
34: <operation op="ADD" params="count,
count, 1, RXrem"/>
35: </condition>
36: </conditional>
25 37: </condition>
38: </conditional>
39: <conditional>
40: <condition cond="EQUAL" params="RXendof-
FrameBar, 0">
41: <transition next="writeLength"/>
30 42: </condition>
43: <condition cond="else" params="" >
44: <transition next="getBody"/>
45: </condition>
46: </conditional>
47: </state>
35 48: <state name="writeLength">
49: <operation op="WRITE_DATA" params="count, 0"/>
50: <operation op="ADD" params="writes, writes, 1"/>
51: <transition next="commitPacket"/>
52: </state>
53: <state name="commitPacket">
40 54: <operation op="COMMIT_WRITE" params=
"writes[9:0]"/>
55: <transition next="startState"/>
56: </state>
57: </states>
58: </FSM>
```

APPENDIX E

```
<connection name="c1">
<src element="sender"port="myout"/>
50 <sink element="receiver_1"port="myin"/>
<sink element="receiver_2"port="myin"/>
</connection>
```

The invention claimed is:

1. A method of designing a memory system for implementation using an integrated circuit, comprising:
 - receiving specification data including attributes of said memory system;
 - configuring a memory component and a memory interconnection component to store messages of a memory model in response to the specification data to generate a logical view of said memory system said memory component is defined by a memory architecture and a memory interface, and said memory-interconnection

25

component is defined by a memory-interconnection architecture and a memory-interconnection interface; and
generating a physical description of said memory system in response to said logical view, said physical description including memory circuitry associated with said integrated circuit defined by said memory component, said memory circuitry having an interconnection topology defined by said memory interconnection component wherein said memory circuitry comprises a plurality of memories, and wherein said memory architecture is configured to store said messages within said plurality of memories.

2. The method of claim 1, further comprising:
defining said specification data using a set of primitives configured to generate descriptions for said memory system attributes.

3. The method of claim 2, wherein said set of primitives comprises extensible markup language (XML) constructs.

4. The method of claim 1, wherein said memory circuitry is disposed within said integrated circuit.

5. The method of claim 1, wherein a portion of said memory circuitry is disposed within said integrated circuit, and a remaining portion of said memory circuitry is disposed external to said integrated circuit.

6. The method of claim 1, wherein said memory system is configured to store messages, wherein said memory circuitry comprises a single memory, and wherein said memory architecture is configured to store all of said messages in said single memory.

7. An apparatus for designing a memory system for implementation using an integrated circuit, comprising:
means for receiving specification data including attributes of said memory system;
means for configuring a memory component to store messages and a memory interconnection component of

26

a memory model in response to the specification data to generate a logical view of said memory system said memory component is defined by a memory architecture and a memory interface, and said memory-interconnection component is defined by a memory-interconnection architecture and a memory-interconnection interface; and
means for generating a physical description of said memory system in response to said logical view, said physical description defining memory circuitry associated with said integrated circuit defined by said memory component, said memory circuitry having an interconnection topology defined by said memory-interconnection component wherein said memory circuitry comprises a plurality of memories, and wherein said memory architecture is configured to store said messages within said plurality of memories.

8. The apparatus of claim 7, further comprising:
means for defining said specification data using a set of primitives configured to generate descriptions for said memory system attributes.

9. The apparatus of claim 7, wherein said memory circuitry is disposed within said integrated circuit.

10. The apparatus of claim 7, wherein a portion of said memory circuitry is disposed within said integrated circuit, and a remaining portion of said memory circuitry is disposed external to said integrated circuit.

11. The apparatus of claim 7, wherein said memory system is configured to store messages, wherein said memory circuitry comprises a single memory, and wherein said memory architecture is configured to store all of said messages in said single memory.

* * * * *